



INSTALLATION, SERVICE AND MAINTENANCE INSTRUCTIONS

LOBE PUMP SLR



INOXPA, S.A.

c/Telers, 54 Aptdo. 174

E-17820 Banyoles

Girona (Spain)

Tel. : (34) 972 - 57 52 00

Fax. : (34) 972 - 57 55 02

Email: inoxpa@inoxpa.com

www.inoxpa.com



MANUFACTURER DECLARATION
According the EC directive about machines
98/37/CE, Annex II B

The manufacturer:

INOXPA, S. A.

c/ Telers, 54

17820 Banyoles (Girona) - Spain

Hereby declares, that the pumps

_____	_____	_____
Denomination	Type	Manufacturing year

Comply with the pertinent disposition, in the execution supplied by **INOXPA, S.A.** for the incorporation in a machine or installation, or for the assembly with other machines as a subunit of other higher order machine.

Harmonized norms used, particularly:

EN 292 part 1 and 2, EN 809

The machine above must not be put into service until the machinery into which it has been incorporated have been declared in conformity with the EC Machinery Directive. It must meet, particularly, the standards EN 294, EN 563, EN 809 y EN 953 in its respective current editions.

Year of CE marking: CE 95
Banyoles, January 1995



Marc Pons Bague Technical Manager

EC DECLARATION OF CONFORMITY
According the EC directive about machines
98/37/CE, Annex II A

The manufacturer:

INOXPA, S. A.

c/ Telers, 54

17820 Banyoles (Girona) - Spain

Hereby declares, that the pump

_____	_____	_____
Denomination	Type	Manufacturing year

Are in conformity with the essential requirements of the Machinery Directive 98/37/CE (latest modifications included) and according the following Council Directives and harmonized norms:

- 72/23/CE Directive "low voltage"
- Norms EN 292 part 1 and 2, EN 809

Year of CE marking: CE 95
Banyoles, January 1995



Marc Pons Bague Technical Manager

1. Introduction

CHECK THE SHIPMENT.

The first thing to do when the pump is received is to check it and ensure that the contents conform to the shipping voucher. INOXPA inspects all equipment prior to shipment, but it cannot guarantee that the merchandise reaches the user intact. Therefore, the pump and any other article received should be checked and in the event the item in question did not conform to specifications and/or was missing a/some part(s), the transportation company should prepare a report as soon as possible. Each pump bears a serial number engraved on the plate. Indicate the serial number on all documents and correspondence.

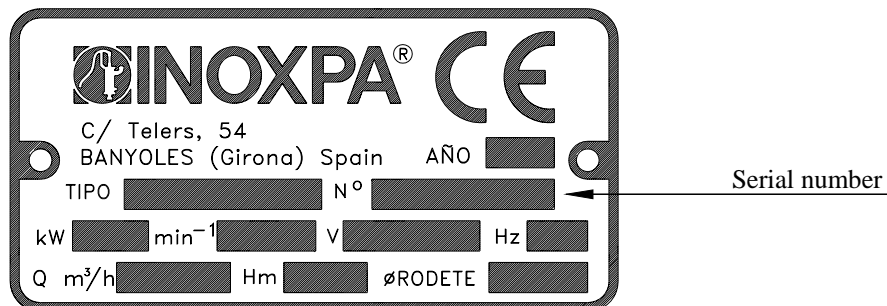

Figure 1.1: Serial number engraved on the manufacturer's plate

If the pump is not put into service upon arrival, a complete revolution of the shaft should be made once a week.

INSTRUCTIONS MANUAL.

The information provided in the instruction manual refers to updated data. We reserve the right to modify the design and/or manufacturing specifications of our products as required, devoid of any obligation on our part to adapt any product supplied prior to such alteration. The technical information made available in this instruction manual, together with the graphs and technical specifications provided, shall continue to belong to us and should not be used (except for starting up this installation), copied, photocopied, made available or otherwise given to third parties without our prior written consent. INOXPA is reservation the right to modifying this instructions manual without previous notice.

START-UP INSTRUCTIONS.

This instruction manual contains vital and useful information for properly operating the pump and for keeping it in good running condition. It also contains important instructions for avoiding possible accidents and serious damage that could be produced prior to its start-up and during its installation, thereby ensuring its handling in the safest way possible. Please read the instructions carefully before operating the pump and familiarize yourself with its operation, following very carefully the instructions provided. We wish to stress the importance of being informed on how to perform the installation correctly. It is extremely important to keep these instructions in a secure place close to the installation.

MAINTENANCE.

This pump, like any other machine, requires routine maintenance. Chapter 9, "Technical specifications", deals with the identification of the spare parts. It is intended for the use of technical and maintenance personnel and for those persons responsible for supplying spare parts.

OPERATING PRINCIPLES.

A. Safety.



This symbol indicates those safety instructions contained in this manual which when not followed could jeopardize your safety



This symbol indicates potential problems with electrical safety.



This symbol indicates a compulsory measure to be taken by the user in compliance with specific instructions which serve to guarantee operating safety and/or protection of the pump.

B. Technical principles.

Quantity	Symbol	Unit
Dinamic viscosity	μ	mPa.s (=cP=Centipoise)
Kinematic viscosity	$V=\mu/\rho$	with ρ =specific weight [Kg/dm ³] and V = kinematic viscosity [mm ² /s] = cSt = Centistoke
	Only the dynamic viscosity is used in this manual.	
Pressure	p	[bar]
	Δp	[bar] - differential pressure
	Pm	[bar] - maximum pressure at discharge mouth (design pressure)
Unless otherwise indicated, in this manual pressure is understood to be relative pressure.		
Net positive suction head (NPSH)	NPSH [m]	
	<p>In this manual, NPSH = NPSHr (NPSH required for the pump). NPSHr = the net pressure above the liquid vapour pressure at pumping temperature and at the pump inlet connection required to avoid performance impairment due to cavitation at rated capacity. NPSHr is measured at the suction flange at the point where the capacity drop = 4% of the rated capacity, and is corrected to the datum elevation. NPSHa = the total suction pressure available from the system at the pump suction connection, minus the vapour pressure if the liquid at pumping temperature. NPSH available is calculated for the installation. It is the responsibility of the user to determine this value.</p> <p style="text-align: center;">NPSHa \geq NPSHr + 0,5</p>	

SAFETY

Symbols.

It is absolutely necessary to place symbols on the pump, e.g., arrows which indicate the direction of rotation or other symbols indicating connections to fluids. All of these symbols should be clearly visible and legible.

Training and experience.

The personnel who are responsible for the operation, maintenance, inspection and assembly of the equipment should have the proper experience and training. The scope of their responsibilities and the supervision of the operators should be specifically defined by the plant foreman.

If the operators did not have the required knowledge, they should be trained, which could be done by the manufacturer of the machine or by the supplier on behalf of the shop foreman.

Furthermore, the shop foreman should make sure that the contents of the instruction manual are fully understood by the operators.

In accordance with the instructions.

Any failure to comply with the instructions could lead to a hazard for the operators, the atmospheric conditions of the room, and the machine, and it could lead to a loss to any right to make a claim for damages.

Such non-compliance could bring with it the following risks:

- Important operating failures of the machine / plant.
- Failure to comply with specific maintenance and repair procedures.
- Potential electrical, mechanical and chemical hazards.
- Atmospheric conditions in the room could be hazardous due to the release of chemical substances.

In accordance with the regulations governing safety at work.

The instructions contained in this manual should be followed for operating the pump, along with national regulations and any other service and safety instructions made available by the shop foreman, so as to avoid accidents.

Safety instructions for handling.

If the machine's components, whether in a cold or warm state, constitute some hazard, then accidental contact with the same should be avoided.

When the machine is operating, be sure that the rotating parts are protected by a shield.

In the event of a fire (e.g., mechanical seal) of hazardous fluids (e.g., explosives, toxic agents, hot products), the machine should be emptied to prevent any risk to persons or to the ambient conditions. Existing regulations should be strictly adhered to. Avoid any hazard which could be produced by the electrical circuits (e.g.: VDE specifications and regulations on the supply of local energy services).

Safety instructions for maintenance, inspection and assembly.

It is the shop foreman's responsibility to see to it that maintenance, inspection and assembly work is performed by qualified personnel once they have become familiar with the subject; they should read this manual very carefully.

Work should only be done on this machine when it is stopped; it is extremely important that the procedure for stopping the machine be followed as set forth in this manual.

Those pumps should be de-contaminated which may contain hazardous agents.

Upon completion of the work, re-install the safety and protection devices.

Prior to re-initiating the operation of the machine, the instructions given in the chapter on "Operating Principles" should be read.

Changes without prior authorization and production of spare parts.

No modification can be made to the machine without the prior consent of the manufacturer. For your safety, use spare parts and accessories authorized by the manufacturer.

The use of other parts exempts the manufacturer from any and all responsibility.

Unauthorized operations.

The machine's safety is only ensured if it is used properly in accordance with the instructions given in this manual.



The limits for values specified in the data sheet cannot be exceeded under any circumstances.

Any change in operating conditions can only be done with the prior written consent of INOXPA.

WARRANTY.

We wish to point out that any warranty issued will be null and void and that we are entitled to an indemnity for any civil liability claim for products which might be filed by third parties if:

- operation and maintenance work has not been done following the corresponding instructions; the repairs have not been made by our personnel or have been made without our written authorization;
- modifications are made to our material without prior written authorization;
- the parts or lubricants used are not original INOXPA parts/lubricants;
- the material has been improperly used due to error or negligence or have not been used according to the indications and the intended purpose.

The General Delivery Terms which you have already received are also applicable.

INOXPA SERVICE.

In the event of doubt or should you require a fuller explanation on particular data (adjustment, assembly, disassembly...), please do not hesitate to contact us..

2. Table of Contents

1. Introduction

Check the shipment	1.1
Instructions manual	1.1
Start-up instructions	1.1
Maintenance	1.1
Operating principles	1.1
Safety	1.2
Warranty	1.3
INOXPA Service	1.3

2. Table of Contents

3. General Information

Description	3.1
Principle of operation	3.1
Noise	3.1
Application	3.1
Hygiene	3.2
Materials used in its construction	3.2
Field of application	3.2
Shaft sealing	3.3
Safety valve	3.4

4. Installation

General considerations	4.1
Instructions for reception, transport and storage	4.1
Weights	4.1
Location	4.2
Stability	4.2
Handling	4.3
Assembly instructions. Electric motors	4.3
Speed variators and reducers	4.4
Coupling	4.4
Direction of rotation	4.5
Suction an discharge pipes	4.5
Secondary piping	4.7

5. Start-up

General considerations	5.1
Pre-start-up procedures	5.1
Cleaning	5.1
Start-up	5.1
Safety valve	5.2
Shut-down the pump	5.3
Troubles	5.3
Instruction for re-using and disposal	5.3

6. Maintenance

General considerations	6.1
Preparations	6.2
Comprovation in the maintenance	6.2

Conservation	6.2
External cleaning	6.2
Electrical installation	6.3
Oiling	6.3

7. Operating Problems

8. Disassembly and Assembly

General considerations	8.1
Disassembly and assembly. Pump housing	8.2
Disassembly of the lobes and the seal cartridges	8.2
Mechanical seal and shaft sleeve	8.3
Changing the lip seals	8.4
Assembly of the shaft sleeve and the pump cover -cartridges-	8.5
Fitting the lobes	8.5
Pump housing	8.5
Adjusting the lobes	8.7
Disassembly and assembly of the safety valve	8.8

9. Technical Information

Technical data	9.1
Frame of the particles	9.2
Materials	9.2
Torque	9.3
Dimensions SLR pump	9.4
Dimensions SLR 1-2-3 (vertical inlets)	9.5
Dimensions SLR 4-5 (vertical inlets)	9.6
Dimensions pump with flushing and/or heating jacket around sealing and on pump cover.....	9.7
Dimensions pump with safety valve and heating jacket on pump cover	9.8
Dimensions <i>zb</i>	9.9
Dimensions flange connections to DIN 2633 PN 16 and DIN 2634 PN 25	9.10
Dimensions rectangular inlet	9.11
Hyclean SLR 0-10	9.12
Parts list Hyclean SLR 0-10	9.13
Hyduty SLR 0-20 / 0-25	9.14
Parts list Hyduty SLR 0-20 / 0-25.....	9.15
Hyclean SLR 1-20	9.16
Parts list Hyclean SLR 1-20.....	9.17
Hyclean SLR 1-25 /1-40	9.18
Parts list Hyclean SLR 1-25 / 1-40	9.19
Hyduty SLR 2-25	9.20
Parts list Hyduty SLR 2-25	9.21
Hyclean SLR 2-40 / 2-50	9.22
Parts list Hyclean SLR 2-40 /2-50	9.23
Hyduty SLR 3-40	9.24
Parts list Hyduty SLR 3-40	9.25
Hyclean SLR 3-50 /3-80	9.26
Parts list Hyclean SLR 3-50 / 3-80	9.27
Hyduty SLR 4-50	9.28
Parts list Hyduty SLR 4-50	9.29
Hyclean SLR 4-100 / 4-150	9.30
Parts list Hyclean SLR 4-100 / 4-150	9.31
Hyclean SLR 5-125 / 5-150	9.32
Parts list Hyclean SLR 5-125 / 5-150	9.33
Safety valve Hyclean	9.34
Front heating jacket Hyclean	9.35

Heating jacket around shaft sealing Hyclean	9.36
Heating jacket around shaft sealing Hyduty	9.37
Flushing SLR 0 - 1	9.38
Flushing Hyclean SLR 2 - 3 - 4 - 5.....	9.39
Flushing Hyduty SLR 2 - 3 - 4	9.40
Single mechanical seal SLR 0 - 1	9.41
Single mechanical seal Hyclean SLR 2 - 3 - 4 - 5	9.42
Single mechanical seal Hyduty SLR 2 - 3 - 4	9.43
Lip seal PTFE SLR 0 - 1.	9.44
Lip seal PTFE Hyclean SLR 2 - 3 - 4 - 5.....	9.45
Lip seal PTFE Hyduty SLR 2 - 3 - 4	9.46
O-ring SLR 0 - 1	9.47
O-ring Hyclean SLR 2 - 3 - 4 - 5	9.48
O-ring Hyduty SLR 2 - 3 - 4	9.49
Lip seal INOXPA SLR 0 - 1	9.50
Lip seal INOXPA Hyclean SLR 2 - 3 - 4 - 5	9.51
Lip seal INOXPA Hyduty SLR 2 - 3 - 4	9.52
Packing gland SLR	9.53
Single mechanical seal DIN 24960 Hyduty SLR 2 - 3 - 4	9.54
Double mechanical seal Hyduty SLR 2 - 3 - 4	9.55

10. Cleaning and Disinfection

General considerations	10.1
Hygiene	10.1
Safety in cleaning and disinfection	10.2

3. General Information.

DESCRIPTION.

The Hyduty and Hyclean lobe pumps by INOXPA are part of our wide range of positive displacement rotary pumps for viscous liquids.

The following models exist in the lobe pump range:

- The Hyclean pump normal flow rate suitable for pressures of up to 12 bar.
- The Hyclean with wider lobes, delivers a higher flow rate, and is suitable for pressure of up to 7 bar.
- The Hyduty pump for pressure of up to 22 bar.

The Hyclean model has been specially developed to respond to all hygienic requirements in the food industry.

As regards hygiene, reliability and sturdiness, the complete range of lobe pumps satisfies all requirements set by the aforesaid industry.

Its modular design enables optimal part interchange between the different pumps.

PRINCIPLE OF OPERATION.

The lobe pump is a positive displacement rotary pump. The top lobe is driven by the driving shaft. The lower lobe is located on the driven shaft, and is driven via a helical gear. Both lobes rotate in synchronism without one touching the other. When the pump is running they displace a set volume of liquid. Figure 3.1 shows how a lobe pump operates.

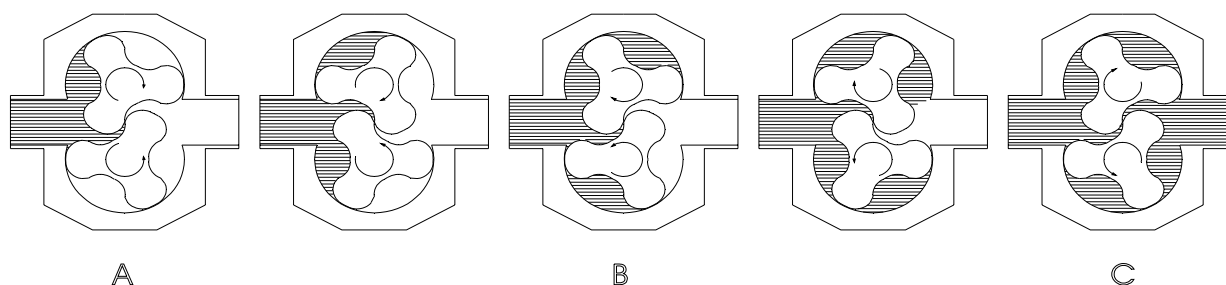

Figure 3.1: Operating principle

A: When the lobes rotate, the space on the suction side increases because one lobe moves away from the other, thus causing a partial vacuum that draws the liquid into the pumping chamber.

B: Each lobe void is filled consecutively as the shafts rotate and the liquid is displaced towards the discharge side. The small clearances between the lobes, and between the lobes and the walls of the pump body duly cause the spaces to be rather well closed.

C: The pump body is completely full and the liquid leaks through the meshing of the lobes, knocking against the space walls so as to thus complete the pumping action.

NOISE.

The lobe pumps are rotary displacement pumps. Owing to the contact between the internal parts, the pressure variations, etc. They make a louder noise than centrifugal pumps. This noise must be taken into consideration when installing these pumps.



When the noise level in the operating area exceeds 85 dB(A), a special protection shall be installed.

APPLICATION.

The main advantage of the INOXPA lobe pump is its capacity to pump a great variety of viscous liquids, from 1 mPa.s up to 100.000 mPa.s

Furthermore, it is capable of pumping liquid products that require very careful handling and liquids that contain soft solids thus causing only a minimum degradation of same.

HYGIENE.

Special attention has been given to hygiene and cleaning requirements in the construction of the pump. The number of grooves and dead spaces have been limited to an absolute minimum. Furthermore, no liquid can enter between the lobes and shafts.

The Hyduty and Hyclean rotary lobe pumps by INOXPA have been approved by the American 3A Standard Authorities.

MATERIALS USED IN ITS CONSTRUCTION.

All pump parts which are in contact with the product are stainless steel, or are made of tasteless and odorless materials. This makes the pump resistant to corrosion and avoids contamination of the liquid being pumped



It is necessary to check and verify that the materials (of the parts in contact with the product) are adequate for pumping a product which is specifically for human consumption.

Table 3.1: Parts in contact with the liquid

Part	Material
Pump housing	AISI-316 (1.4408)
Pump cover	AISI-316 (1.4401)
Lobe	AISI-316 (1.4401)
Cover for shaft sealing	AISI-316 (1.4401)
Lobe screw	AISI-316 (1.4401)
Piston safety valve	AISI-316 (1.4401)
Shaft sleeve*	AISI-316 (1.4401)

*shaft sleeve for shaft sealing options L, O and I are hardened by surface treatment.

Table 3.2: Parts which can be in contact with the liquid

Part	Material
Shaft	AISI-304 (1.4460)
Jacket mechanical seal	AISI-316 (1.4401)

FIELD OF APPLICATION.

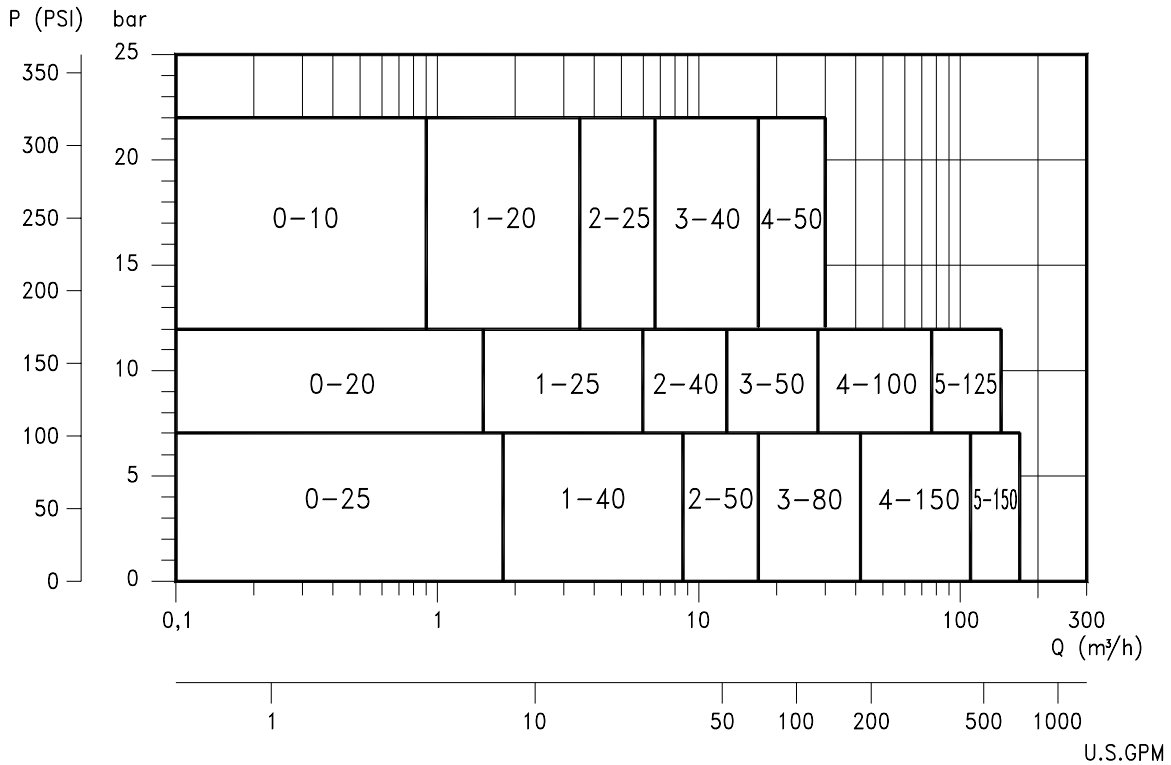

Figure 3.2: Field of application



The field of application for each type of pump is limited. The pump was selected for certain pumping conditions at the time that the order was passed. INOXPA assumes no responsibility for damages that may arise in the event that the information made available by the purchaser is incomplete (nature of the liquid, viscosity, r.p.m. ...).

Do not use the pump for applications other than those for which it has been specified on purchase and installation. No modifications can be made without previously consulting with INOXPA and without the latter's written consent. A correct application shall take into account the following: the viscosity of the product, its properties, purity, temperature, suction and discharge pressure, r.p.m. ...

When the pump is used in a pumping unit or in an environment for which the pump has not been designed, the operator and the material may be exposed to hazard. Consult INOXPA in case of doubt prior to use.

Refer to Table 3.3 and the corresponding notes for value limits (viscosity, temperature, pressure...).

Table 3.3 : Field of application.

	HYCLEAN		HYDUTY
	Normal capacity	High capacity	High pressure
Theoretical flow rate litres /100 min ⁻¹	555 litres	662 litres	50 litres
Maximum flow rate	133 m ³ /h	159 m ³ /h	29 m ³ /h
Maximum pressure	12 bar	7 bar	22 bar
Maximum connections	125 mm	150 mm	50 mm
Maximum temperature	110 °C	110 °C	180 °C
Maximum viscosity (recommended)	100.000 mPa.s.	100.000 mPa.s.	100.000 mPa.s.
Maximum speed	950 min ⁻¹	950 min ⁻¹	1500 min ⁻¹

The maximum viscosity allowed will depend on the nature of the liquid and the sliding speed of the seal faces. Consult INOXPA should the viscosity be still greater.

WARNING The following limits ought to be considered for the:

- **Heating jacket:** temperature max. 180°
pressure max. 4 bar
- **Flushing:** flow 2,5 - 5 l/min.
pressure max. 0,5 bar
- **Elastomers**
 - EPDM:** temperature max. 130 °C
 - VITON:** temperature max. 180 °C
 - NBR:** temperature max. 100 °C
 - PTFE:** temperature max. 180 °C

SHAFT SEALING.

The following options for the mechanical seal are applicable to the entire range of pumps.

- single mechanical seal for the food processing industry
- single mechanical seal to DIN 24960 L₁K (Hyduty).
- a double mechanical seal (Hyduty)

Table 3.4: Materials for faces exposed to friction and internal mechanical seal elastomers

	Rotating part	Stationary part	Elastomers
standard	silicon carbide	graphite	EPDM
options	silicon carbide	silicon carbide	EPDM

- O-ring seal: maximum pressure 15 bar
materials: VITON or EPDM
- PTFE lip seal: maximum pressure 10 bar
materials: PTFE + AISI-316

- Lip seal INOXPA: maximum pressure 7 bar
materials: VITON
- Gland packing: maximum pressure 10 bar
materials: PTFE

SAFETY VALVE.



The positive displacement lobe pumps must be protected from excess pressure when they are operating. Consequently, all the Hyclean and Hyduty pumps can be fitted with a stainless steel safety valve or a safety by-pass.

Protection.

This valve protects the pump and prevents excessively high pressure arising in the circuit. It reduces the differential pressure (Δp) between suction and discharge, but not the maximum pressure within the plant.



Do not use the safety valve to protect the system from excess pressure. It is designed to protect the pump only as it is not a safety outlet.

Operation principle

The safety by-pass valve is located in the housing and prevents excess pressure arising inside the pump. For example, when the pump's discharge mouth is clogged and the liquid cannot be pumped out, too high a pressure can cause serious damage to some of the pump's parts. The safety valve opens a passage from the pump's discharge side to its suction side: an escape route, redirecting the flow again to the suction side whenever specifically high pressure levels are reached. The by-pass is effective in both directions of rotation.



If the safety valve operates, this will mean that the equipment is not working properly. The pump should be disconnected immediately. Identify and solve the problem before re-starting the pump.

**Remember that the safety valve in the pump is not able to be used to regulate the flow rate.
If the safety valve is not fitted in the pump, other steps should be taken to protect the pump from excess pressure.**

Setting.

The safety valve can be adjusted to any determined pressure, according to the type of pump being used.

4. Installation.

GENERAL CONSIDERATIONS.

This manual provides basic instructions which should be taken into account when proceeding to install the pump. It is of utmost importance that the plant foreman reads this manual before installation.

The instructions include pertinent information which will enable you to install your pump / pumping unit correctly. The manual also contains important instructions for preventing eventual accidents and serious damage which could occur prior to start up and during the installation.

It is imperative to put warning markers on the pump, e.g., arrows which indicate the direction of rotation or symbols indicating fluid connections. All these warnings should be clearly visible and legible.

Any failure to comply with the instructions could result in a risk for the operators, the environment and the machine, and could result in the loss of any right to make a claim for damages.

INSTRUCTIONS UPON DELIVERY, FOR TRANSPORT AND STORAGE.

When the machine arrives, read the instructions on page 1 of the chapter titled "Introduction".



SLR pumps and pumping units are often too heavy to be stored manually. Use an adequate means of transport. Use the points which are indicated in the drawing for lifting the pump.

Only authorized personnel should transport the pump. Do not work or walk under heavy loads.

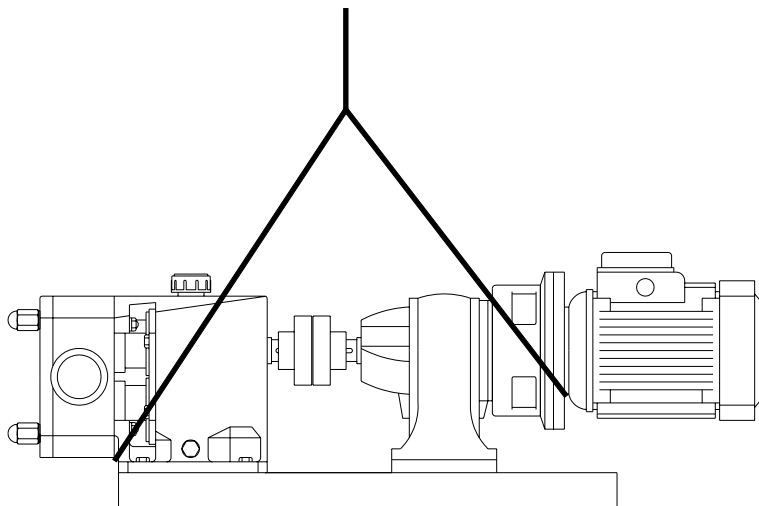
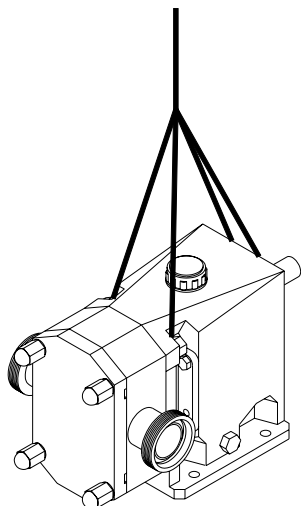

Figure 4.1: Lifting the pump.

WEIGHTS.

Table 4.1: weight of pump with bare shaft end

Types	Pump with bare shaft end [kg.]
SLR 0-10	11,5
SLR 0-20	12
SLR 0-25	13
SLR 1-20	19
SLR 1-25	16
SLR 1-40	17
SLR 2-25	31
SLR 2-40	26
SLR 2-50	28
SLR 3-40	70
SLR 3-50	61
SLR 3-80	65
SLR 4-50	168
SLR 4-100	150
SLR 4-150	165
SLR 5-125	375
SLR 5-150	395

LOCATION.

Piping.

Place the pump or pumping unit as close as possible to the suction tank (refer to chapter, "Pump Installation"), and if possible below the level of the liquid or even lower with regard to the tank so that the static manometric suction head is at its maximum. Place the suction and discharge piping in straight runs with a minimum of elbows and fittings in order to reduce to the greatest extent possible any loss of head caused by friction. This improves the suction conditions, thereby providing maximum performance of the pump.

Accessibility.

Place the pump so that access can be had to the pump and to the drive units so as to make inspections and revisions. Leave sufficient space around the pump / pumping unit for proper inspection, separation of the pump from other units and for maintenance operations. In order to disassemble the SLR pump you should leave sufficient space in front of and behind it. (Chapter 9 deals with the dimensions).

Place the pump / pumping unit with sufficient space for the lifting equipment if the components or the total weight of the unit exceed 22 kg.

Place the pump / pumping unit near the drain on the floor.

It is very important to be able to gain access to the pump or pumping unit connecting device (even when it is operating).

Outdoor installation.

The SLR pump can only be installed out of doors if there is a roof covering it or, if permitted, a special installation is to be made. Consult INOXPA prior to installation.

Indoor installation.

Place the pump so that the motor is properly ventilated. Prepare the motor to be started according to the instructions provided by its manufacturer.



A suitable connection should be used when inflammable or explosive liquids are pumped. Connect the components of the unit with grounding jumpers in order to reduce the danger from static electricity.

Use explosion-proof motors in accordance with local regulations. Provide suitable coupling guards and suitable couplings.

Excessive temperatures.

Depending on the fluid to be pumped, high temperatures can be reached inside and around the pump.



Over 70°C, the operator should take protective measures and place warning notices advising of the danger which exists if the pump is touched.

The type of protection selected should not isolate the pump entirely. It should allow for the bearings to be cooled more efficiently and for the bearings to be lubricated.

STABILITY.

Foundation.

Install the pump base so that the drive and pump are level and well supported. Therefore the pump unit should be installed on a base plate –according to DIN 24259–, or on a frame, both placed exactly level on the foundation. The foundation must be hard, level, flat, vibration free ...to prevent base distortion (to keep the alignment pump –drive guaranteed while commissioning).

To install the pump unit on the foundation proceed as follows:

- Make holes in the foundation to fit foundation bolts. This is unnecessary when expanding screws are used instead of foundation bolts.
- Place base plate or frame with the aid of shims horizontally on the foundation.
- Grout
- When the grout has entirely hardened the pump unit can be placed on the baseplate or the frame. Tighten the nuts on the foundation bolts carefully.
- After unit is installed recheck alignment of pump and motor shaft and alignment of piping. Realign if necessary.
- In the case of applications dealing with high temperatures the pump can be operated temporarily at its working temperature. Then recheck alignment pump - piping.

For other foundations consult INOXPA.

Piping Installation

Piping can be installed horizontally and vertically, provided that the pump remains leveled.

HANDLING.



If the pump is supplied without a drive, the purchaser/user is responsible for the pump's start-up and assembly.

Starting torque.

The starting torque of the positive displacement pumps is almost identical to the rated torque. Make sure that the motor's rated torque is sufficiently high, but check that it does not exceed the maximum torque allowed on the pump shaft (see technical specifications). Consequently, choose a motor with a capacity 25% greater than the power absorbed by the pump.

ASSEMBLY INSTRUCTIONS.

ELECTRIC MOTORS.

Regulations.

Prior to connecting an electric motor to the power supply, check local regulations on electrical safety and also refer to the EN 60204-1 standard.



Let qualified personnel perform the connection of electrical motors. Take the necessary steps to prevent faults in the connections and wiring.

Automatic breaker.

In order to work on the pump without hazards, an automatic breaker should be installed as close as possible to the pump. The use of a grounding switch is also recommended.



The pumps switchgear should comply with current regulations, as set forth in the EN 60204-1 standard on electrical safety.

Protection of the motor against overloads.

In order to protect the motor from overloads and short circuits, the use of thermal or magnetic relays is recommended. Adjust these relays to maximum rated current values as indicated on the data plate of the motor.

Electrical diagram.

	Connection U=...	
	3x220	3x380
motor		
220/380	Δ	Y
380	-	Δ

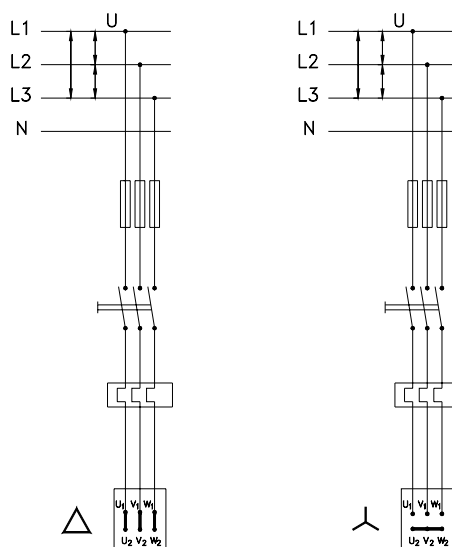

Figure 4.2: SLR pump electrical connections

Connection.

Consult the supplier's instructions prior to connecting the motor to the power supply.

For single-phase motors, use motors with an increased starting torque.

Ensure a starting torque which is sufficiently high for motors controlled by a frequency converter, and provide for adequate cooling at low speeds. If necessary, install an independent fan.



The electrical equipment, the terminals and the control system components can continue to carry current when disconnected. Any contact with them can endanger the safety of the operators or cause irreparable damage to the material.

SPEED VARIATORS AND REDUCERS.

If using speed variator or reducer in the pumping unit, consult the supplier's instruction manual, and the directives numbered under the section "electric motors".

COUPLING.

For the couplings selection and assembly consult to the supplier manual. Sometimes the torque of the positive displacement pumps can be high enough. Therefore, a coupling have been chosen 1.5 to 2 the adequate torque.

Alignment.

The pump and motor shaft of complete units have been accurately pre-aligned in our factory. After installations of the pump unit, the pump and motor shaft should be re-aligned.

Place a straight-edge (A) on top of the coupling: the straight should make contact with both halves of the coupling over their entire length (see figure 4.3).

Repeat the check, but this time on both sides of the coupling near the shaft. For the sake of accuracy, this check should also be done using an outside caliper (B) at two diametrically opposite points on the outside surfaces of the two halves of the coupling.

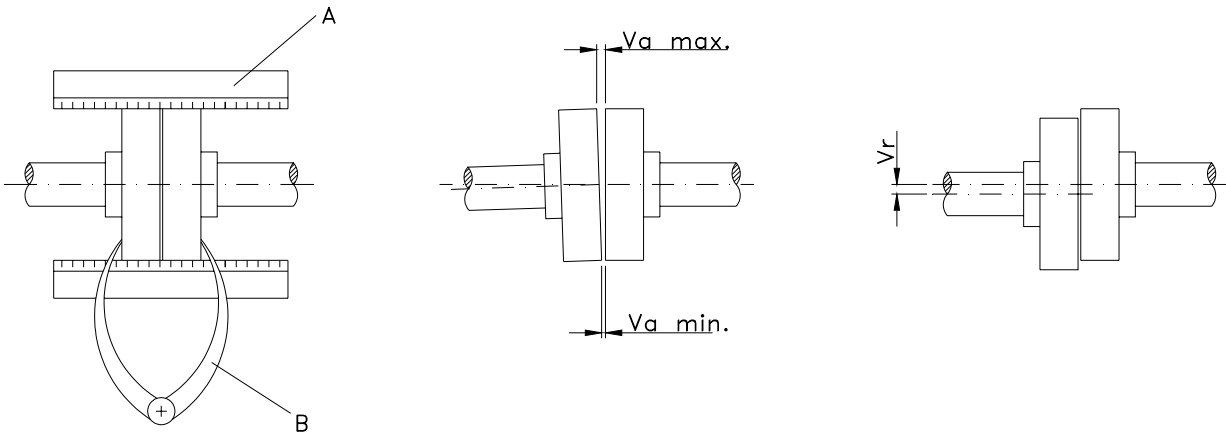

Figure 4.3: coupling alignment.

Table 4.3: Maximum alignment deviations:

Outside diameter of the coupling [mm]	Va min. [mm.]	Va max. [mm.]	Va max. - Va min. [mm.]	Vr. [mm.]
70 - 80	2	4	0,13	0,13
81 - 95	2	4	0,15	0,15
96 - 110	2	4	0,18	0,18
111 - 130	2	4	0,21	0,21
131 - 140	2	4	0,24	0,24
141 - 160	2	6	0,27	0,27
161 - 180	2	6	0,3	0,3
181 - 200	2	6	0,34	0,34
201 - 225	2	6	0,38	0,38

DIRECTION OF ROTATION.

The direction of rotation determines the location of the pump's suction and discharge mouths.

The standard rotation direction is clockwise looking from the rear end of the motor, displacing the fluid from right to left (see figure 4.4).

However, it is easy to invert the rotating direction and therefore vary the fluid's flow direction.

If for a form determined of assembly is better a pump with a drive shaft in the lower position, can fit an standard pump quickly and easily.

- standard, direction of rotation is clockwise looking from the rear end of the motor.
- standard, direction of rotation is inverted from clockwise.
- optionally, can be place the shaft driver in the lower support of the pump.
- optionally, with support to vertical inlets.

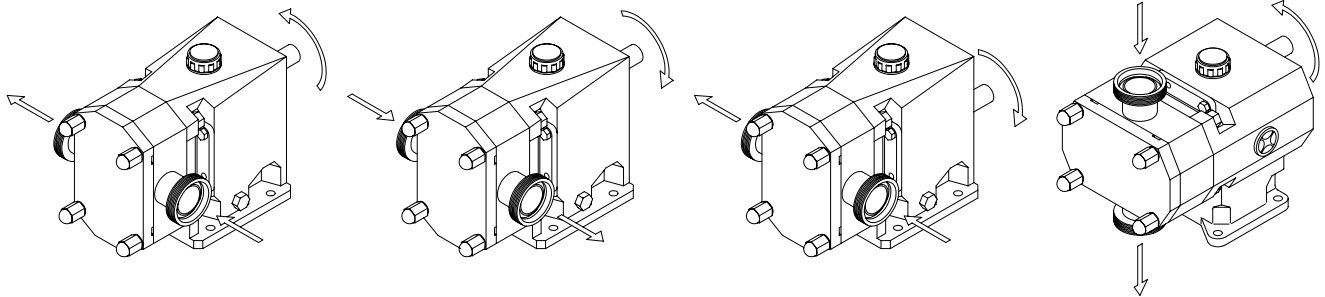

Figure 4.3: direction of rotation



Make sure that the pump rotates in the direction indicated on the plate. If the pump rotates in the wrong direction it could cause serious damage.

SUCTION AND DISCHARGE PIPES.

Excessive forces and moments on pump connections, caused by the piping, could result in mechanical damage to the pump or pumping unit.

These pipes should be connected in a straight line, without leaving spaces between connections and the faces of parallel connections. Provide for adequate anchoring devices and make sure that they are not tensed too much when the pump is operating.

When hot liquids are pumped, pay attention to thermal expansion; if this is the case, use expansion joints.

Once the connection has been made, check that the shaft can turn freely.

Pipes.

Use pipes with a diameter which is equal to or greater than that of the pump's connections. If the liquid to be pumped is viscous, the loss of head from the suction and discharge pipes can increase considerably. Other pipe components such as valves, elbows, filters and foot valves, can also cause a loss of head.

For this reason, the diameters and the length of pipes and other components should be selected so as not to cause any mechanical wear to the pump/pumping unit, operating within the minimum pressure limits allowed for the suction (refer to NPSH graph), the maximum working pressure (refer to chapter 3, "Field of Application"), and without surpassing the rated motor power.

Suction pipe.

Liquids should be introduced into the pump from a higher level than that of the pump; the pipe should be inclined in its path to the pump and be devoid of air pockets.



A diameter which is too small, a suction pipe which is too long, or a filter that is too small or clogged, will lead to a greater loss of head and thus the NPSH available (NPSHa) can become less than that required (NPSHr). Cavitation may occur, causing noise and vibrations. Under such circumstances, the pump or the pumping unit may be mechanically damaged.

If a filter is installed in the suction mouth, the loss of head in the suction pipe should be constantly checked. Also make sure that the intake pressure at the suction mouth of the pump is sufficiently high (see NPSH).



When the pump is operating in both directions, the loss of head must be calculated for both directions.

Check the tension of the suction pipe after its connection.

Self-priming process.

In general terms --if the self-priming process is followed-- the pump ought to contain sufficient liquid to fill the internal recesses and the void spaces thus enabling the pump to create a pressure difference.

However, if low viscosity fluids are to be pumped, a foot valve of the same or greater diameter as that of the suction pipe should be installed; alternatively, the pump can be installed with a "U" shaped piping.

The use of a foot valve is not recommended for pumping viscous liquids.

In order to eliminate air and gases from the suction pipe, the counter-pressure on the discharge pipe should be reduced. When the self-priming process is used, the pump's start-up should be done by opening and emptying the discharge pipe which allows the air and gases to escape at a low counter-pressure.

Another possibility involves long pipes or when a check valve is installed in the discharge pipe; it is also possible to install a by-pass with a shut-off valve on the discharge side of the pump. This valve shall be opened in the case of priming and will allow air and gases to escape at a minimum counter-pressure.

The by-pass should not lead back to the intake orifice but to the supply tank instead.

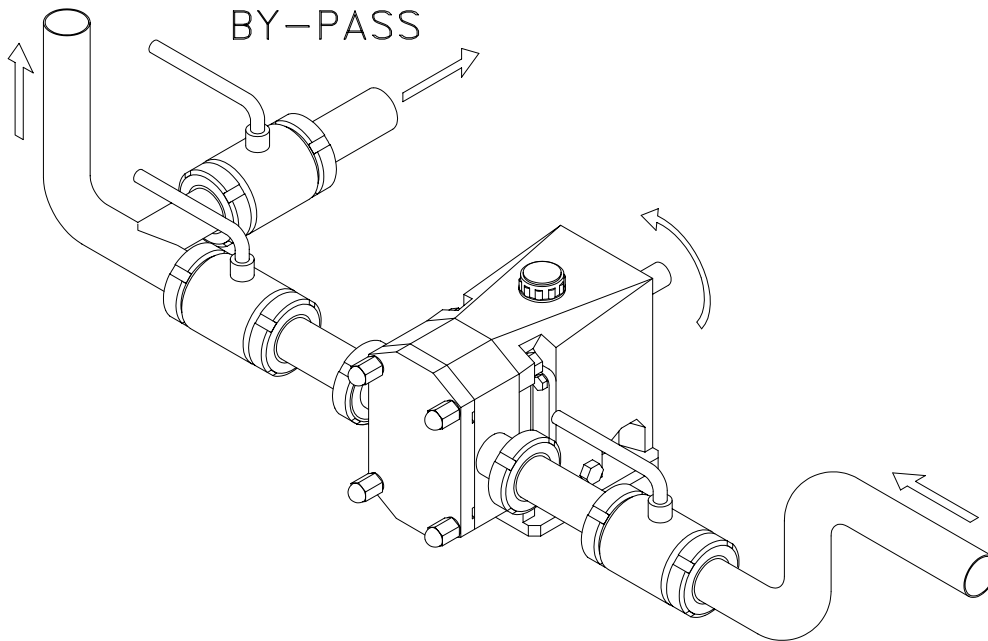

Figure 4.5: main piping.

Shut-off valves.

For a proper maintenance, the pump should be isolated. This isolation can be obtained by installing shut-off valves in the suction and discharge pipes of the pump.

These valves should be able to open completely, both for suction and for discharge, up to the full passage of suction and discharge pipes (ball-valves or sluice valves are preferable).



**When the pump is started up, the shut-off valves should be completely open.
The flow rate should never be regulated by closing the shut-off valve in the suction or discharge pipe.**

The flow rate is to be regulated by increasing or decreasing the pump's speed or by using a by-pass which re-directs the flow to the supply tank.

Filters.

Foreign particles can seriously damage the pump. Avoid the entry of these particles by installing a filter.

When selecting a filter, bear the diameter of the screen openings in mind so that loss of head will be minimal. The filter diameter should be three times greater than that of the suction pipe.

The filter should be placed in such a way that it does not interfere with maintenance and cleaning operations. Be sure that the density of the liquids is appropriate and that they can be filtered easily.

Refer to Chapter 9 ("Technical Specifications") for information on the maximum frame permitted for foreign particles.

SECONDARY PIPING.

Flushing.

If the seal requires flush media, the media supply and the purchase and installation of piping, valves ... for the media are not the responsibility of INOXPA.

The flush shaft seal option (F) is available on all seal types. Use the sectional drawings of the SLR seal options in chapter 9 to purchase additional parts.



Attention should be given to the compatibility of the handled liquid with the flush media. Choose the sealing liquid so that unwanted chemical reactions are avoided. Also check the compatibility of the slush media with seal elastomers.

SLR housings have female threaded inlet and outlet connections and are dependent upon frame of the pump and type of flush system employed. Consult figure 4.6 for an overview of connections provided.

Liquid flush media.

Use a flush media which is filtered free from impurities to obtain maximum service life of the seal. If the product is sticky or crystalline then use media which is able to dissolve the product.

Connect the flush so that the inlet is at the bottom and outlet is at the top. This will make a better evacuation or air or gases possible.

Heating / cooling jackets.

Heating / cooling jackets (S) are available on the front cover or/and around the seal. Heating or cooling media can be provided via connections according to figure 4.8.

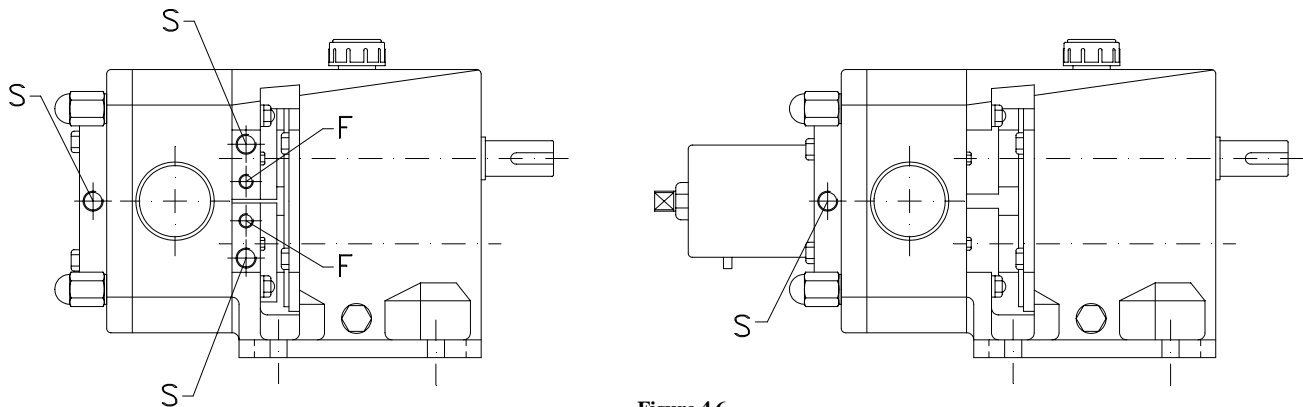

Figure 4.6

5. Start-Up.

GENERAL CONSIDERATIONS.

The pump can be started up so long as the instructions given in chapter 4 ("Installation") have been followed.



Prior to start-up, the persons responsible for the operation must be duly informed of the pump / pumping unit's operation and the safety instructions. This instruction manual should be available to personnel at all times.

Prior to start-up, check the pump or pumping unit for any possible failure. If a failure is found, the plant foreman should be notified immediately.

Also consult the section "Dimensions" in chapter 9.

PRE-START-UP PROCEDURES.

- Prepare the motor or other drive for operating according to instructions provided by motor manufacturer.
- Check the electrical supply to see that it matches the motor nameplate rating.
- Check coupling alignment.
- Make sure all product contact parts and seal parts are clean. If necessary dismantle and clean by hand (Follow instructions of chapter 8).
- Check that the pump is protected from the ingress of foreign bodies are installed.
- The interior of the pump, the suction and the discharge pipes must be absolutely free of all foreign material.
- Check if all main and all secondary piping (flushing) is connected, tight and leak free.
- Check oil level of the pump. Add correct grade of oil as necessary to maintain level in centre of oil sight glass (in the case of first start-up: pumps are shipped with oil in the gearbox, nevertheless this check may be skipped).



Do not overfill! See chapter "Maintenance".



Prior to start-up, substitute the blind stopper for transportation, by the stopper of gases exit supplied in a bag of plastic.

- Lubricate motor or other drive for manufacturer's instructions.
- All guards must be secured in position.

CLEANING.



Prior to start-up, check to see that the pipes and the pump are completely clean and devoid of weld splatterings or other foreign particles.

Consult chapter 10 (cleaning and disinfection) on how to properly clean your SLR pump and the cleaning methods and liquids which should be used.

START-UP.

- Fully open the isolating valves in the suctions and discharge pipelines.
- In case of a seal flush: start the flush media flowing and adjust pressure and flow.
- If the liquid does not flow into the pump, fill it with the liquid to be pumped.



The pump should never rotate when empty. Provide flushing if necessary.

- If the pump is fitted with heating / cooling jackets, open the isolating valves to admit the heating / cooling agent. Wait for at least 15 minutes until the pump and the liquid in the pump have reached the required service temperature.
- Manually give the pump shaft a few turns, to make sure that the pump is not blocked.
- Open the isolating valves in the flushing line, if any, before the seal. See also chapter "Installation".

- Check to see if the pump can be started up safely.
- Start the pump.
- Check to see whether the absolute intake pressure is sufficient, so that no vapour can be emitted inside the pump. Refer to the curve for the minimum pressure required above the vapour pressure (NPSH).
- Control the discharge pressure.



A shut-off valve installed in the suction pipe should not be used to regulate the flow rate. It must remain completely open during the pump's operation.

- Check if the liquid flow is established.
- Check if connections and seals are not leaking.



If no fluid is pumped, leaking appear or if excessive noise is apparent, the pump must be stopped immediately. Consult chapter 7 (trouble shooting) to determine the problem. Correct before restarting the pump. If abnormal symptoms persist, the pump must be taken out of service immediately. Contact the pump manufacturer or appointed agents.

- Adjust safety valve.

SAFETY VALVE.

The valve's opening pressure depends on the fluid to be pumped, its viscosity, its r.p.m....., and so before starting-up the pump, the operator ought to adjust the safety valve's opening pressure.

The safety valve setting.

When the safety valve is equipped this valve has been adjusted to the pump's maximum operating pressure. The operator must check this by observing the position of the pin (55D). When the pin is completely displaced to the pump cover, valve has been set at the pump's maximum pressure.

To obtain the correct opening pressure, the following procedure should be followed:

- Loosen the nut (54C).
- Using a spanner, turn the adjusting screw (25A) to the right to reduce the spring tension, and thus obtain the required opening pressure. When we make this operation, observe that the pin's position (55D) back up to position of the pump cover.
- If the correct opening pressure has been obtained, tighten the nut (54C).



When checking the safety valve also make sure the pump's pressure will NEVER exceed the pressure setting + 2 bar.



When the safety valve does not work properly, the pump must be taken out of service immediately. The valve must be inspected by an INOXPA service technician.

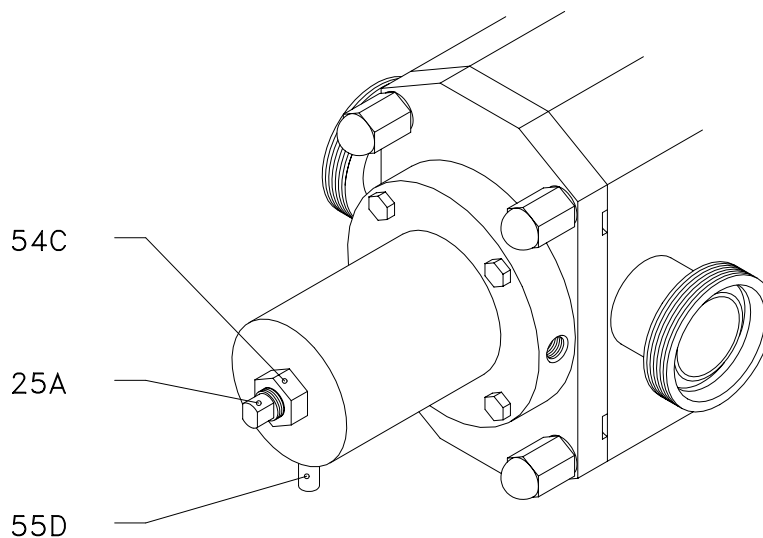

Figure 5.1: Safety valve

6. Maintenance.

GENERAL CONSIDERATIONS.



Inadequate, wrong or improper maintenance could result in the faulty operation of the pump, high repair costs, and breakdown in the long run. For this reason the instructions given in this chapter should be followed.

During maintenance operations which are performed on the pump, whether due to inspections, preventive maintenance or the movement of the installation, the procedures indicated should always be followed. Failure to comply with these instructions could endanger the operator and/or seriously damage the pump or pumping unit. Maintenance work should only be done by qualified personnel. Wear appropriate clothing which provides adequate protection against high temperatures and hazardous and/or corrosive fluids. Make sure that the personnel read the entire instruction manual and, in particular, indicate to them the chapters which refer to work which needs to be done. INOXPA does not assume responsibility for accidents and damage which might occur as a result of any failure to comply with the instructions indicated herein.

Construction.

The geometry of the lobe bases on the synchronized operation of the two lobes, without that they enter in contact between them.

The shaft driven of the bomb is worked for the shaft drive through two helical gears.

The gear drive is fixed to the shaft by means of a cotter and a safety nut.

The gear driven is subject to the shaft for a mechanism of adjustable subjection, they so that the lobes can synchronize without necessity of calipers.

Each one of the shafts goes mounted on a ball bearing of double angular contact and a needle bearing.

In order to drag the lobes, the shafts has of a grooved key seat.

Shafts, gears and bearings could settle like an only module in the support, system of cartridge (figure 6.1), except support 0.

The lubrication of the gears and the bearings are carried out for bathroom of oil. Is used lip seals for the stopper of the shaft with the support.

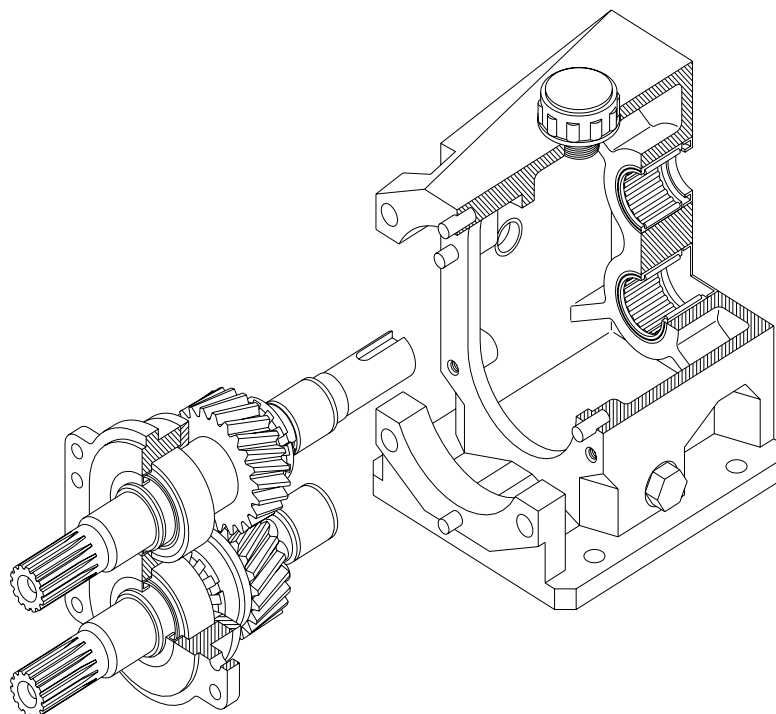

Figure 6.1: support

PREPARATIONS.**Work area.**

Provide for a clean work area; some parts require very careful handling and others are machined to close tolerances.

Tools.

Use tools which are designed for the purpose for which they are to be used in maintenance and repair work. Use them properly.

Disconnection.

Before beginning maintenance and inspection work, disconnect the pump.

Decompress the pump and the pumping unit.

If the fluid to be pumped allows for it, let the pump cool down until it reaches room temperature.

Safety.

Do not let the motor start if work needs to be done on the pump. This is very important when electric motors are involved which are started by remote control.

Follow the procedure outlined below:

- Place the pump switch in the "Off" position.
- Disconnect the pump from the power supply.
- Block the electrical control panel or put a warning notice on it.
- Remove the fuses and take them with you to the work area.
- Do not pull out the protector around the coupling until the pump has completely stopped.

COMPROVATION IN THE MAINTENANCE.

- Periodically check suction and discharge pressures.
- Periodically control a leak:
 - Verify the oil of the support.
 - Check the shafts packer (a mechanical seal does not require any maintenance; however, the seal should never be made to work in dry state. Should a leak occur, replace the seal.
- Check the oil level weekly. If necessary, add oil (after the pump has stopped) **Do not fill too much !** see the section "oiling".
- Verify the oil look. If the oil is contaminated, drain utterly the support (after the pump has stopped), search the origin of contamination, corrected it and then fill the support with oil, see the section "oiling".

CONSERVATION.

Should the pump be taken out of service for a long period of time:

- First of all, empty the pump.
- Apply VG46 mineral oil to the internal parts.
- The pump should be worked on for a brief period of time once a week or the shaft rotated manually. This ensures the correct circulation of the protective oil.

EXTERNAL CLEANING.

Attempt to keep the exterior of the pump clean at all times. This helps in inspection work and keeps warning notices visible. Make sure that cleaning products do not get into the motor's ball bearings. Cover all parts which should not enter into contact with the cleaning fluid.

The cleaning products should not come into contact with the lip seals.



Do not spray hot parts of the pump with water as some components could crack due to quick cooling and the fluid inside the pump could spill out.

ELECTRICAL INSTALLATION.



Maintenance work on electrical installations can only be done by qualified personnel and only when the power supply has been cut off. Carefully follow national safety regulations.

Also abide by the regulations referred to above if you are working while the power supply is still connected.



Check to see whether the electrical materials to be cleaned are well protected (for example, IP 54 indicates protection against dust and water spray but does not include protection against pressure water jets). Refer to EN 60529. Choose an appropriate method of cleaning electrical materials.

Replace defective fuses with new ones having the prescribed amperage.

On finishing each maintenance operation, check the electrical installation components to see if they are defective and repair them if necessary.

OILING.

The gears and bearings are oiled by immersion in an oil bath (see table 6.1. to the quantity).

The pumps are supplied with oil.

- Regularly check the oil level, for example, weekly or every 150 operating hours.
- The first oil change must be carried out after 150 hours of operation.
- Afterwards, it can be changed every 2500 operating hours or at least once a year when operating under normal conditions.

When change the oil: the oil sump must be filled up to the level in the middle of the peephole.

DO NOT POUR TOO MUCH OIL INTO THE SUMP ! Leave the pump switched off for a while and then re-check the oil level; if necessary, add a little oil.

Oils for environment temperatures of 5 to 50°C: **SAE 90** or **ISO VG 220**.

Table 6.1: quantity of oil in each support

Types	Quantity of oil in the support (l.)
SLR 0	0,3
SLR 1	0,5
SLR 2	0,75
SLR 3	1,75
SLR 4	4,5
SLR 5	15

7. Operating Problems.

Problems	Probable Causes
Overloading of motor	8, 9, 12, 16, 20, 21, 22, 23, 24, 26.
Insufficient discharge flow rate	2, 4, 5, 7, 8, 9, 10, 11, 13, 14.
No pressure on the discharge side	1, 2, 3, 6, 7.
Irregular discharge flow rate/pressure	2, 4, 5, 6, 9, 12.
Noise and vibrations	2, 4, 5, 6, 7, 8, 9, 11, 12, 13, 16, 19, 20, 21, 22, 23, 24, 25, 26.
The pump gets clogged	8, 9, 11, 16, 19, 20, 21, 22, 24, 25, 26.
Overheating of pump	7, 8, 9, 11, 12, 16, 20, 21, 22, 23, 24, 26.
Abnormal wear	4, 5, 11, 15, 16, 19, 24, 25.
Leak through mechanical seal	17, 18, 27.

Probable causes		Remedies
1	Wrong rotation direction	Invert the rotation direction
2	Insufficient NPSH	Increase available NPSH: - Rise the suction tank - Lower the pump - Reduce the speed - Increase the diameter of the suction pipe - Shorten and simplify the suction piping.
3	Pump not purged	Purge or fill
4	Cavitation	Increase suction pressure (see 2)
5	The pump sucks in air	Check suction pipe and all its connections.
6	Suction pipe clogged	Check the suction pipe and filter(s), if any.
7	Wrong setting of safety valve	Check the safety valve's setting
8	Discharge pressure too high	If necessary, reduce the loss of head by increasing the diameter of the discharge pipe
9	Viscosity of the liquid is too high	- Reduce the pump speed - Reduce the viscosity, for example, by heating the liquid..
10	Viscosity of liquid too low.	- Increase the pump speed - Increase the viscosity, for example, by cooling the liquid.
11	Temperature of liquid too high.	Reduce the temperature by cooling the liquid.
12	Pump speed too high	Reduce the pump speed
13	The lobes are worn	Replace the lobes
14	Pump speed too low	Increase the pump speed
15	Product very abrasive	Fit hardened lobe hubs
16	Worn bearings	Replace the bearings, check the pump
17	Worn or damaged mechanical seal	Replace the seal
18	O-rings not the right ones for the liquid	Fit the proper O-rings; check with the supplier.
19	Worn gears	Replace and readjust the gears
20	Insufficient lubricating oil level	Fill up with oil
21	Unsuitable lubricating oil	Use an appropriate oil
22	The lobes rub	- Reduce the temperature - Reduce the discharge pressure - Adjust the play
23	Coupling misalignment	Align the coupling
24	Tension on the pipelines	Connect the pipelines to the pump free of tensions
25	Foreign bodies in the liquid	Insert a filter in the suction pipe
26	Pump and / or electric motor not fixed on foundation	Tighten, check that the piping has been connected stress-free and align the coupling
27	Mechanical seal spring tension too low	Adjust as indicated in this manual



If the problems persist stop using the pump immediately. Contact the pump manufacturer or his representative.

8. Disassembly and Assembly.

GENERAL CONSIDERATIONS.

The assembly and disassembly of the pumps should only be done by qualified personnel. Make sure that the personnel read carefully this instruction manual and, in particular, those instructions which refer to the work they will perform.



Incorrect assembly or disassembly may cause damage in the pump's operation and lead to high repair costs and a long period of down-time.

INOXPA is not responsible for accidents or damages caused by a failure to comply with the instructions in this manual.

Preparations.

Provide for a clean working environment as some parts, including the mechanical seal, require very careful handling and others have close tolerances.

Check that the parts which are used are not damaged during transport. When doing this, you need to inspect the adjustment edge, the butted faces, the tight fit, burrs, etc.

After each disassembly, carefully clean the parts and check for any damage. Replace all damaged parts.

Tools.

Use the proper tools for assembly and disassembly operations. Use them correctly.

Tightening torque.

Table 8.1: Tightening torque.

Material	Tightening torque N.m.								
	M5	M6	M8	M10	M12	M14	M16	M18	M20
8.8	6	10	25	49	86	135	210	290	410
A2	5	9	21	42	74	112	160	210	300

Cleaning.

Before disassembling the pump, clean it on the outside and on the inside.



NEVER clean the pump by hand when it is running.

Safety.

Prevent the motor from starting if you need to work on the pump.

Take steps to ensure that the motor cannot be started if the pump housing has been removed, for example, for cleaning operations.

NEVER cause the pump to run without the housing.



Disconnection.



Before beginning disassembly and assembly work, disconnect the pump. Decompress the pump and the pumping unit.

If the fluid in the pump allows for it, let the pump cool off until reaching room temperature.

Electrical safety.

Prevent the motor from starting if you need to work on the pump. This is very important when working with electric motors that are started by remote control.

Follow the procedure outlined below:

- Place the pump switch in the "Off" position.
- Disconnect the pump from the control panel.
- Block the electrical control panel or put a warning notice on it.
- Remove the fuses and take them with you to the work area.
- Do not put out the protector around the coupling until the pump has completely stopped.

**DISASSEMBLY AND ASSEMBLY.
PUMP HOUSING.**

- Close the suction and discharge valves.



ATTENTION! The liquid can spill out when the pump housing is removed.

- Remove the wing nuts (45). Grooves are provided on 4 places along the circumference to permit removing the pump cover with the aid of, say, a screwdriver, if need be.
- Check to see that the O-ring (80A) is in good condition.
- Make sure that the O-ring is not inverted when inserted. If the O-ring is made out of PTFE, it is advised to heat it in hot water before placing it in the groove. A warmed-up PTFE O-ring becomes more supple, thus easier to mount.
- Once the pump cover is assembled, the wing nuts must be tightened (crosswise).

DISASSEMBLY OF THE LOBES AND THE SEAL CARTRIDGES.

Remove the pump cover as indicated in the foregoing section.

- Remove the lobe screws (25) using a wrench, as shown in figure 8.1. These screws are threaded to the right. Wooden or nylon blocks can be placed between the lobes to stop them from rotation (blocks position: one to the left in front of the top lobe screw and the other to the right in front of the lower lobe screw).
- Check that the O-ring (80) is in good condition.

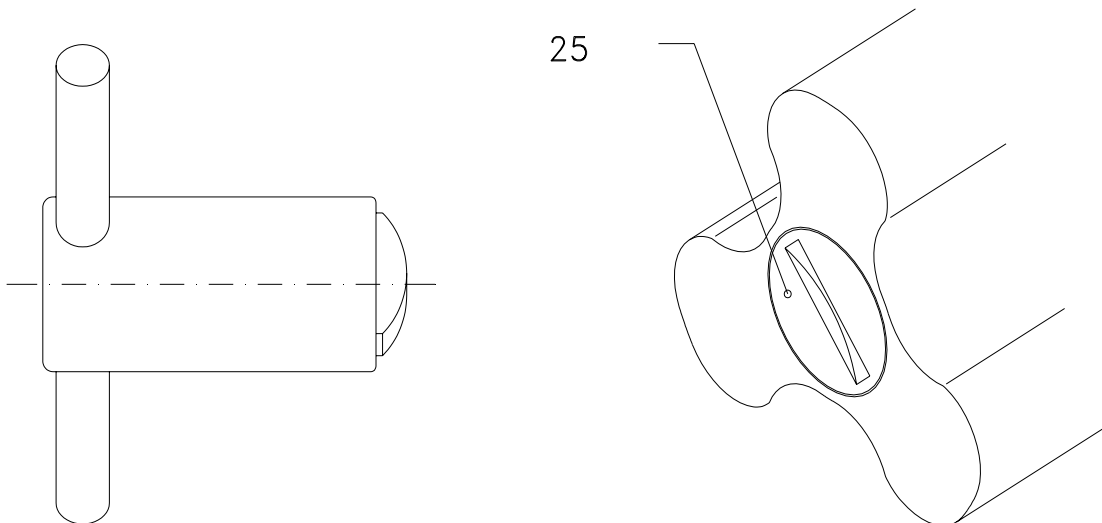

Figure 8.1: Wrench

Support 0 y 1:

- Press the notches so that the both lobes (02) and the pump cover are loosened. If necessary, use a suitable tool.
- Unscrew the allen screws (51B, support 0) or the nuts (54A, support 1) that attach the pump housing to the support. Remove the pump casing.
- Remove the allen screws (51C) that subject the pump cover (09) with the pump housing. With a mechanical seal, the rotating seal ring stays on the shaft sleeve.

Support 2, 3, 4 y 5:

- Unscrew the nuts (57) of the seal cartridge, but leave them a few pitches on the stud.
- Push on the nuts (57) to release both lobes and the seal cartridges. Use an auxiliary tool if need be.
- Once the nut have been removed, it is possible to remove the lobes and the seal cartridges of the shaft from the pump housing. With a mechanical seal, the rotating seal ring stays on the shaft sleeve.

MECHANICAL SEAL AND SHAFT SLEEVE.

Mechanical seal, G

- One time the pump cover (09) has been disassembled, as indicated in the foregoing section, take out the seal cover (09A) - the stationary part of the mechanical seal (08A) comes out of the pump cover -. Measures have been taken to avoid that this face could rotate simultaneously with the shaft. Check that the rubbing face and the O-rings are in good condition. The rotating part of the seal (08) remains in the shaft liner (13).
- Dismantle the shaft sleeve (Hyclean:13/13C; Hyduty: 13F/13G). If this liner is stuck to the shaft, a screwdriver, for example, can be introduced in between the liner and the shaft.
- Check that the sealing surface of the rotary face, the O-ring and the shaft liner are in good condition.
- If the adjustment ring in the rotating part of the mechanical seal is dismantled, it must be readjusted when the seal and liner are assembled, and placed at the end of the liner and positioned between the shaft's two dragging pivots; see figure 8.2. and table 8.2.. Then, the rotating part of the mechanical seal (08) with the O-ring and the spring can also be mounted.

Table 8.2: mechanical seal adjustment

Type	A (mm)
SLR 0-10	8
SLR 0-20 / 0-25	8
SLR 1-20	15,5
SLR 1-25 / 1-40	9,5
SLR 2-25	23
SLR 2-40 / 2-50	11
SLR 3-40	32
SLR 3-50 / 3-80	20
SLR 4-50 / 4-100 / 4-150	-
SLR 5-125 / 5-150	-

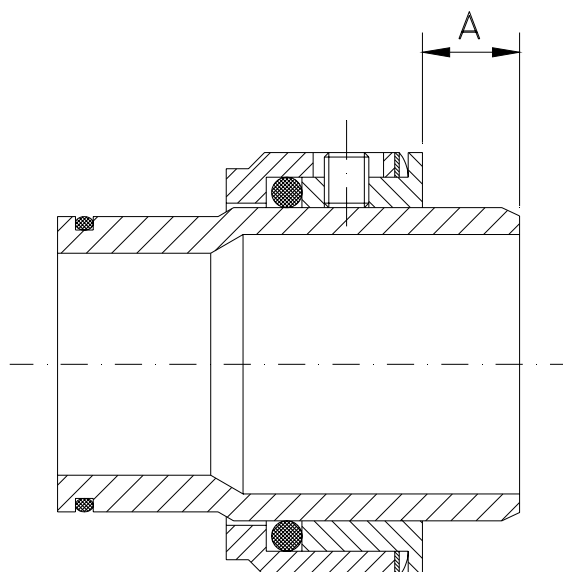

Figure 8.2: assembling the mechanical seal

Seal with PTFE lip seal, L.

- Disassembly the pump cover -cartridge- (support 0 and 1:09C: support 2, 3, 4 and 5 : 09), see disassembly cartridge, the lip seal sale from the pump housing.
- Now the lip seal is visible in the seal cover.
- Check if the lip seal element (08D) is in good condition. If necessary, the lip seal element can be replaced after the lip seal cover (09C) has been removed.
- Check if the shaft sleeve (13A/13D) is in good condition. To disassembly the liner see the instructions above.
- Slightly grease the liners local to the lip seal element before assembly of the lip seal cover.

Seal with O-ring, O

- During disassembly of the cartridge (support 0 and 1: 09C; support 2, 3, 4 and 5: 09), -see instructions above- the O-ring seal has already come out off the outer pump housing. The O-ring seal remains in the seal retainer (support 1, 2 and 3: 09B; support 0, 4 y 5: 09D).
- Check if the O-ring (08B) is still good condition and, if necessary, replace it.
- Check if the shaft sleeve (13A/13D) is still in good condition. For the disassembly procedure of the shaft sleeve see instructions above.
- Slightly grease the shaft sleeve local to the O-ring before assembly of the seal cartridges.

Seal with lip seal INOXPA, M.

- During disassembly of the cartridge (support 0: 09E; support 1, 2, 3, 4 and 5: 09), -see instructions above- the lip seal M has already come out off the outer pump housing. The lip seal remains in the seal retainer (09B).
- Check if the lip seal M (08C) is still good condition and, if necessary, replace it.
- Check if the shaft (13A/13B/13D) is still in good condition. For the disassembly procedure of the shaft sleeve see instructions above.
- Slightly grease the shaft sleeve local to the lip seal before assembly of the seal cartridges.

Single mechanical seal to DIN 24960, N.

- After the disassembly of the lobes, shaft sleeve (13J) together with the rotating part of the mechanical seal (08E) can be pulled out.
- The stationary ring of the mechanical seal (08E) is pulled out in the cover (10B).
- Check condition of sliding faces, the O-rings and the shaft sleeves. If necessary, replace them.

Double mechanical seal, D.

- Disassembly the lobes (02), see instructions above, and remove the nuts (54A) that fit the pump casing with the support. Detach the pump casing.
- The mechanical seal with the shaft sleeve can be pulled out into the pump casing.
- Loosen nuts (57). The double mechanical seal (08F) and the pump cover (09) remain loosen.
- Check that the o-rings (80B and 80L) is still in good condition, and then change the mechanical seal.

Seal with flushing, G, L, O₂ and M and / or with heating.

With these versions, the pump is going provided of additional covers, flushing (10) and heating jacket (10A) respectively, with an o-ring (80M, support 0 and 1) or gasket (18, support 2, 3, 4 and 5).

- The seal itself can be disassembled as outlined in the instructions of disassembly of the mechanical seal (G), the lip seal (L), the O-ring (O) and the lip seal (M), -see instructions above-.
- If the seal housing has to be disassembled for flushing or heating, first dismantle the outer pump housing (see further).
- Loosen nuts (54) and take out studs (support 3 and 4: 55E) or (support 2) loosen bolts (52C).
- Undo the allen screws (51B).
- Separate the housing from the outer pump casing by tapping with a plastic hammer (it is located with pins).
- Take out the flat gasket (18) –this must always be replaced when reassembling.

Gland packing.

- For the utilization of the packing is necessary cut it to hand and shape its ring.
- Upon cutting the rings, coil the packing around the jig of same diameter from the shaft sleeve and then cut them in bevel of 45°.
- The rings will be introduced one by one on the shaft sleeve (13A, 13D, 13E), with the outphasings sections 90° mutually, and then with the hand tighten the stuffing box (37).
- It is let to operate with constant leakage some 10 minutes and tighten the stuffing box (37) through the hexagonal nut (54) until reducing the leakage at an acceptable level (15 to 20 drops/minute). The leakage in the form of drip is essential for the normal operation to assure that the rings does not overheat.

CHANGING THE LIP SEALS.

- In order to change the lip seals (89), the housing have to be disassembled first. See the corresponding section in the manual, and bleed the oil sump.
- Lubricate the shafts in the relevant lip seal position.
- Fill the oil sump once the lip seals have been changed.

ASSEMBLY OF THE SHAFT SLEEVE AND THE PUMP COVER -CARTRIDGES-

- Slide the shaft sleeves on the shafts. With a mechanical seal, first mount the rotating seal ring on the shaft sleeve. Refer to disassembly seal.
- Mount the O-rings (80D) on the shaft sleeves.

Support 0 and 1

- Position the stationary part (08A) of the mechanical seal in its location in the cover.
- Fit the bearing cover (09A) in the pump cover (09) and tighten the allen screws (51C). Then, mount the pump housing seeing his correct instructions.

Support 2, 3, 4 and 5

- Slide the pump cover –cartridges- (09) or spacer sleeve (09A, Hyduty) in the pump housing. Observe that the O-ring (80B) do not damage. With a mechanical seal, can be fit previous stationary part (08A) over the pump cover –cartridge-
- Tighten the nuts (57) on the studs (55).

FITTING THE LOBES.

New lobes to be fitted must be adjusted, and so this should be done first.

- Slide the lobes onto the shafts as far as the shaft sleeve. Observe the markings (0 - 1 and ●); see figure 8.4.
- Rotate the driving shaft a few times and make sure that the lobes do not touch each other. If necessary, refer to the section describing how to adjust the lobes.
- Check that the O-rings (80) of the lobe screws (25) are still in a good condition and that they are correctly positioned in the groove.
- Fit the lobes with the screws (25) and the washers (35). Tighten the screws with a wrench as shown in figure 8.1. A wooden or nylon block can be placed between the lobes to avoid that they rotate simultaneously.
- Check that the front parts of both lobes are aligned.
- Make sure that the clearance both behind and between the lobes is similar to that shown in table 8.3, figure 8.5.

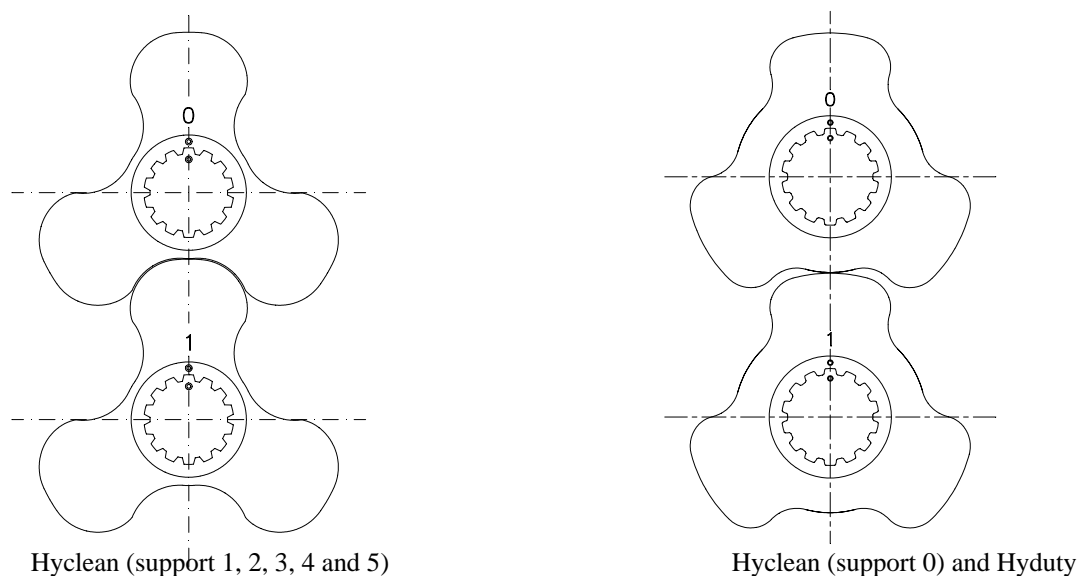

Figure 8.4

PUMP HOUSING.

The pump casing can be disassembled after the removal of the pump cover, the lobes and the seal –cartridges- (supports 2, 3, 4 and 5).

- Unscrew the 4 nuts (54A) from the studs (55A/55B) or allen screws (51B, support 0).
- Release the outer pump casing from the gearbox by tapping on it with a plastic hammer.



Pay attention, during the reassembly of the pump casing, to the location of the dowel pins (56).

Mount the nuts (54A) with the spring washers (53) or fit the allen screws (51B, support 0). Tighten the nuts with the prescribed tightening torque, see table 8.1.

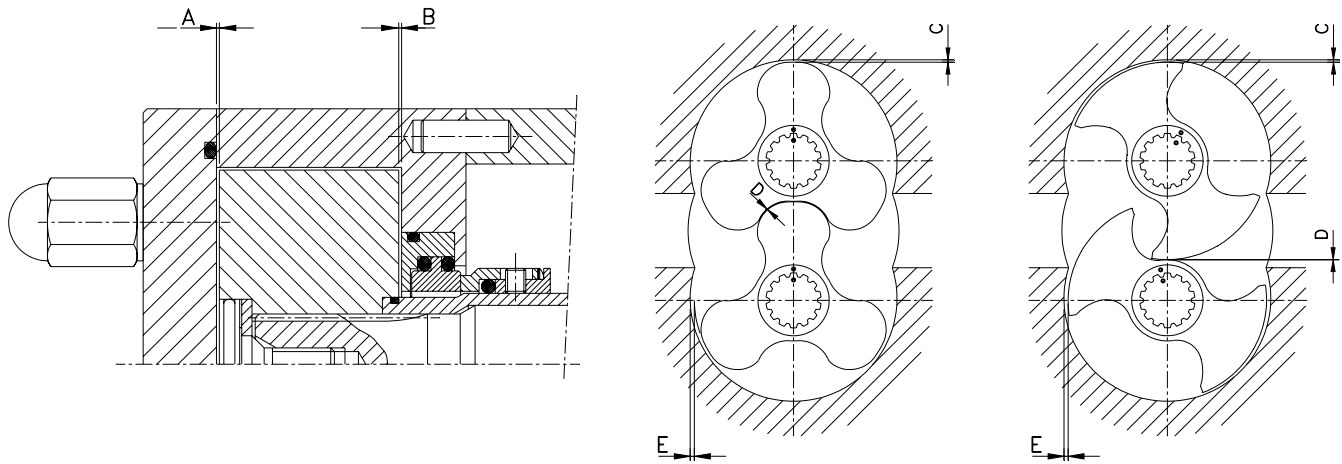

Figure 8.5

Table 8.3: SLR pump clearances and tolerances.

(mm)	A	B	C	D	E
SLR 0-10	0,1 ±0,05	0,06 ±0,03	0,15 ±0,05	0,15 ±0,05	0,35 ±0,05
SLR 0-20	0,12 ±0,05	0,07 ±0,03	0,15 ±0,05	0,15 ±0,05	0,35 ±0,05
SLR 0-25	0,15 ±0,05	0,08 ±0,03	0,2 ±0,05	0,15 ±0,05	0,4 ±0,05
SLR 1-20	0,2 ±0,05	0,2 ±0,05	0,15 ±0,05	0,2 ±0,05	0,35 ±0,05
SLR 1-25	0,15 ±0,05	0,1 ±0,05	0,15 ±0,05	0,15 ±0,05	0,35 ±0,05
SLR 1-40	0,15 ±0,05	0,1 ±0,05	0,2 ±0,05	0,15 ±0,05	0,4 ±0,05
SLR 2-25	0,2 ±0,05	0,2 ±0,05	0,15 ±0,05	0,15 ±0,05	0,35 ±0,05
SLR 2-40	0,2 ±0,05	0,15 ±0,05	0,15 ±0,05	0,15 ±0,05	0,35 ±0,05
SLR 2-50	0,2 ±0,05	0,15 ±0,05	0,2 ±0,05	0,15 ±0,05	0,4 ±0,05
SLR 3-40	0,3 ±0,05	0,3 ±0,05	0,25 ±0,05	0,25 ±0,05	0,55 ±0,05
SLR 3-50	0,25 ±0,05	0,2 ±0,05	0,2 ±0,05	0,2 ±0,05	0,4 ±0,1
SLR 3-80	0,3 ±0,05	0,2 ±0,05	0,3 ±0,1	0,2 ±0,05	0,5 ±0,1
SLR 4-50	0,3 ±0,05	0,3 ±0,05	0,2 ±0,1	0,2 ±0,05	0,65 ±0,1
SLR 4-100	0,3 ±0,05	0,3 ±0,05	0,4 ±0,1	0,3 ±0,05	0,85 ±0,1
SLR 4-150	0,45 ±0,05	0,35 ±0,05	0,6 ±0,1	0,3 ±0,05	1,05 ±0,1
SLR 5-125	0,45 ±0,05	0,35 ±0,05	0,5 ±0,1	0,45 ±0,05	0,95 ±0,1
SLR 5-150	0,45 ±0,05	0,35 ±0,05	0,6 ±0,1	0,45 ±0,05	1,05 ±0,1

A = axial clearance between the lobe and the pump cover.

B = axial clearance between the lobe and back side pump casing.

C = radial clearance between lobe and the pump casing top and bottom

D = radial clearance between lobes

E = radial clearance between lobe and pump casing at inlet and outlet

Dimensions in mm.

ADJUSTING THE LOBES

To adjust the lobes, the shaft unit, gears and bearings must be removed from the support (except support 0). Before must be disassembled the pump cover, the lobes and the seals, as indicated in the relevant section.

- Empty the oil from the support, remove the oil plug (85) and the bleed-emptying plug (87).
- If necessary, disassembly the semicoupling of the driver shaft and remove the key way (61A) of shaft.

Support 0

- Remove the screws (51D) and disassemble the back cover (12B), checking that the o-ring (80E) is not stick to both sides, if it necessary, release the o-ring.
- Place the support, shaft and gears in the bench screw.

Supports 1, 2, 3, 4 and 5

- Remove the screws (51D / 52) which have been used to attach the bearing cover (12) in the support (06). These screws are centred respectively by means of two centring pins (56 / 56A).
- Tap smoothly on the end of the shaft driver-end with a plastic hammer. When the bearing housing is slightly loosened from the support, make sure the seal (18A) –to the bearing bracket 4 check the O-ring (80E)- does not stick to both sides. If necessary, loosen the seal.
- Remove the bearing cover, shafts and gears and place it in the bench screw.
- Loosen the take up screws of the adjustable fastening mechanism for the driven gear (19A), see figure 8.6. In theory, the take up unit is self-releasing. It is now possible to rotate the driving shaft, whilst the driven shaft can be held stationary.

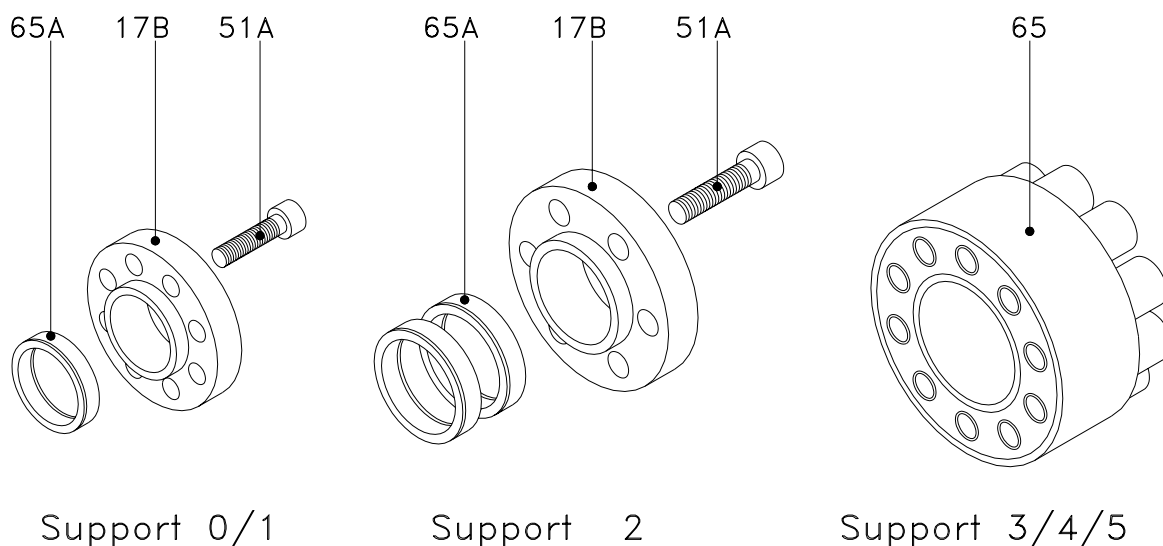

Figure 8.6: adjustable fastening mechanism

Support 0, 1 and 2: the adjustable fastening system is made up of three parts : Allen screws (51A), conical tightening rings (65A) and dragging bushing (17B) .

Support 3, 4 and 5: the adjustable fastening system consists in one single part, (65).

- Slide the lobes onto the shafts as shown in figure 8.4. Press the lobes against the shaft liner.
 - Now rotate the lobes to the position indicated from figure 8.7. Then, rotate a little the both lobes one reference the other, until the clearance (throw) has been to indicate for table 8.3.
 - Tighten a few of the adjustable fastening mechanism take up screws by hand.
 - Now rotate the top lobe 60° to the left; see the figure 8.8. Make sure that the clearance in this position is the same as that between the lobes in the position shown in figure 8.7.
- If not so, this clearances should equal rotating a little a lobe and stopping the other.

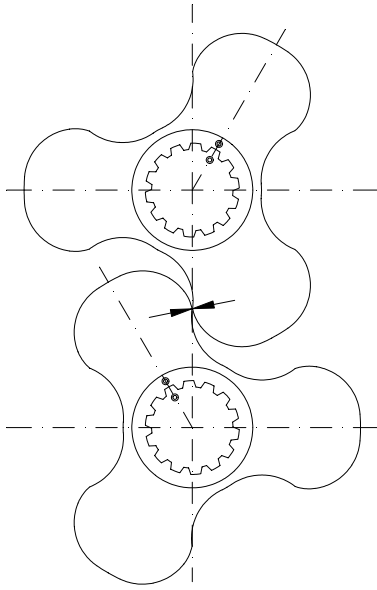

Figure 8.7

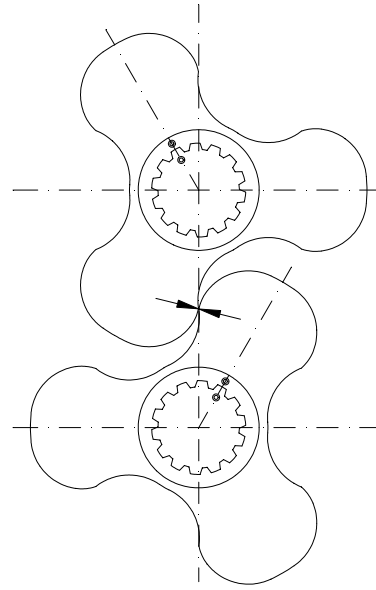

Figure 8.8

- Tighten the adjustable fastening mechanism take up screws crosswise in 2 or 3 passes and with the established tightening torque.
- When tightening the adjustable fastening mechanism screws, take care to avoid that the gears rotate with regard to each other. This can be prevented by placing a wooden wedge between the gears.
- Re-check the mutual clearance between the lobes and rotate the driving shaft a few times to make sure that the lobes do not rub together at all.
- Remove the lobes from the shafts.
- Slightly grease the driver shaft at the place where the oil seal (88) will come after the assembly.

Supports 0

- Check that the o-ring (80E) has not been damaged and stick it with a little grease or oil in the correct position against the bearing house flange.
- Fit the screws (51D / 52) with their washers (53A) and for tighten with tightening torque from the table 8.1.

Supports 1, 2, 3, 4 and 5

- Check that the seal (18A) –for the bearing bracket 4 check o-ring- for the bearing house has not been damaged and stick it with a little grease or oil in the correct position against the back cover (12B).
- Slide the shaft, gear and bearing in the bearing bracket. Take care of the pins (56 / 56A), the needle bearings (70A) and the oil seals (88).
- Fit the screws (51D / 52) with their washers (53A) and for tighten with tightening torque from the table 8.1.

The pump can now be assembled according to the method mentioned earlier.
Fill the oil sump with the recommended oil type; see oiling instructions.

DISASSEMBLY AND ASSEMBLY OF THE SAFETY VALVE.

The safety valve may only be disassembled after the pump has been shut down.



The spring of the safety valve must be without tension, adjusted to the minimal, to the see section “the safety valve setting”.

- Loosen bolts (52B).
- Detach the complete spring casing (01A). The piston (20) will remain mounted on the pump cover.
- Blockade the adjusting screw (25A) with a wrench and unscrew the lock nut (57). Loosen the spring plate (17C) and the spring (75)

Assembly safety valve.

- Check that the seal (80H) is still good condition. and, if necessary, replace it. Put in the spring casing complete.
- Slide the spring (75) and the spring plate (17C) in the inside of spring casing complete. Tighten the lock nut (57).
- Verify that the o-ring (80F), is still good condition. Put in the spring casing complete.
- Check that o-ring (80G) is still good condition. Fit in the piston.
- Insert the piston (20) in the pump cover (03B).
- When fit the spring casing complete (01A) in the pump cover, the piston has been coupled between the pump casing and spring plate.
- Tighten the screws (52B)



Before starting-up the pump is necessary do the adjustment of the safety valve. Proceed according to the section "the safety valve setting".

9. Technical Information.

TECHNICAL DATA.

TYPE	$n_{\text{máx.}}$ [min ⁻¹]	B_1 [mm]	D_1 [mm]	V_{s-100} [l]	Q_{th} [m ³ /h]	$P_{\text{máx.}}$ [bar]	V_u [m/s]	V_i [m/s]
SLR 0-10	1450	10	47,84	1,03	0,9	22	3,63	3,18
SLR 0-20	1450	21	47,84	2,1	1,8	12	3,63	1,76
SLR 0-25	950	29	47,84	3	1,7	7	2,38	0,96
SLR 1-20	1450	24	59,8	3,85	3,35	22	4,70	3,07
SLR 1-25	950	30	69,15	9,96	5,67	12	3,44	2,97
SLR 1-40	950	42	69,15	13,94	7,94	7	3,44	1,95
SLR 2-25	1.450	30	74,25	7,43	6,5	22	5,83	3,5
SLR 2-40	950	42	87,65	23,39	13,33	12	4,36	3,27
SLR 2-50	950	54	87,65	30,08	17,14	7	4,36	2,43
SLR 3-40	1.200	42	111,4	23,4	16,85	22	7	4,13
SLR 3-50	720	54	131,5	67,7	29,25	12	4,96	4,14
SLR 3-80	720	76	131,5	95,28	41,16	7	4,96	2,22
SLR 4-50	950	54	143,8	50,14	28,58	22	7,15	4,04
SLR 4-100	600	104	169,735	217,226	78,2	12	5,33	2,77
SLR 4-150	600	154	169,735	321,67	115,8	7	5,33	1,82
SLR 5-125	400	129	243,14	554,72	133,13	12	5,1	2,94
SLR 5-150	400	154	243,14	662,22	158,93	7	5,1	2,36

- $n_{\text{máx.}}$ Maximum speed
- B_1 Lobe width
- D_1 Lobe diameter
- V_{s-100} Discharge capacity per 100 rpm.
- Q_{th} Theoretical discharge capacity at $n_{\text{máx.}}$
- $P_{\text{máx.}}$ Maximum operating pressure
- V_u Peripheral speed
- V_i Maximum inlet velocity

FRAME OF THE PARTICLES.



; **WARNING ! only soft particles.**
 < 10 % damage when using trilobe geometry.
 < 2 % damage when using winglobe geometry.

Type	Internal diameter connection [mm]	Maximum theoretical sphere frame [mm]	Recommended maximum theoretical sphere frame [mm]
SLR 0-10	9,5	7,5	2,5
SLR 0-20	15,8	7,5	2,5
SLR 0-25	22,4	7,5	2,5
SLR 1-20	15,8	10	3
SLR 1-25	22,4	20,6	7
SLR 1-40	35,1	20,6	7
SLR 2-25	22,4	12,2	4
SLR 2-40	35,1	25,6	9
SLR 2-50	47,8	25,6	9
SLR 3-40	35,1	18,4	6
SLR 3-50	47,8	38,5	13
SLR 3-80	72,2	38,5	13
SLR 4-50	47,8	21,8	7
SLR 4-100	97,6	45,6	15
SLR 4-150	150	45,6	15
SLR 5-125	125	71,5	23
SLR 5-150	150	71,5	23

MATERIALS.

Parts in contact with the liquid.

Part	Item	Material	Material n.
Pump casing	01	CF-8M	1.4408
Pump cover	03	AISI-316	1.4401
Winglobe	02	AISI-316	1.4401
Pump cover	09	AISI-316	1.4401
Lobe screw	25	AISI-316	1.4401
Piston safety valve	20	AISI-316	1.4401
Shaft sleeve*	13 a 13J	AISI-316	1.4401

* shaft sleeves for shaft sealing options L, O y I are hardened by surface treatment.

Parts which can be in contact with the liquid.

Part	Item	Material	Material n.
Shaft	05 /05A	AISI-329	1.4460
Jacket mechanical seal	10A	AISI-316	1.4401

Parts which can not be in contact with the liquid .

Part	Item	Material	Material n.
Heating jacket on pump cover	11	AISI-304	1.4301
Gears	19 / 19A	F-154	1.5732
Bearing cover	12	GG-15	0.6025
Support	06	GG-15	0.6025

TORQUE.

Maximum torque in the pump shaft.

Support	(N.m.)
SLR 0	35
SLR 1	53
SLR 2	108
SLR 3	400
SLR 4	1200
SLR 5	2300

Dimensions SLR pump.

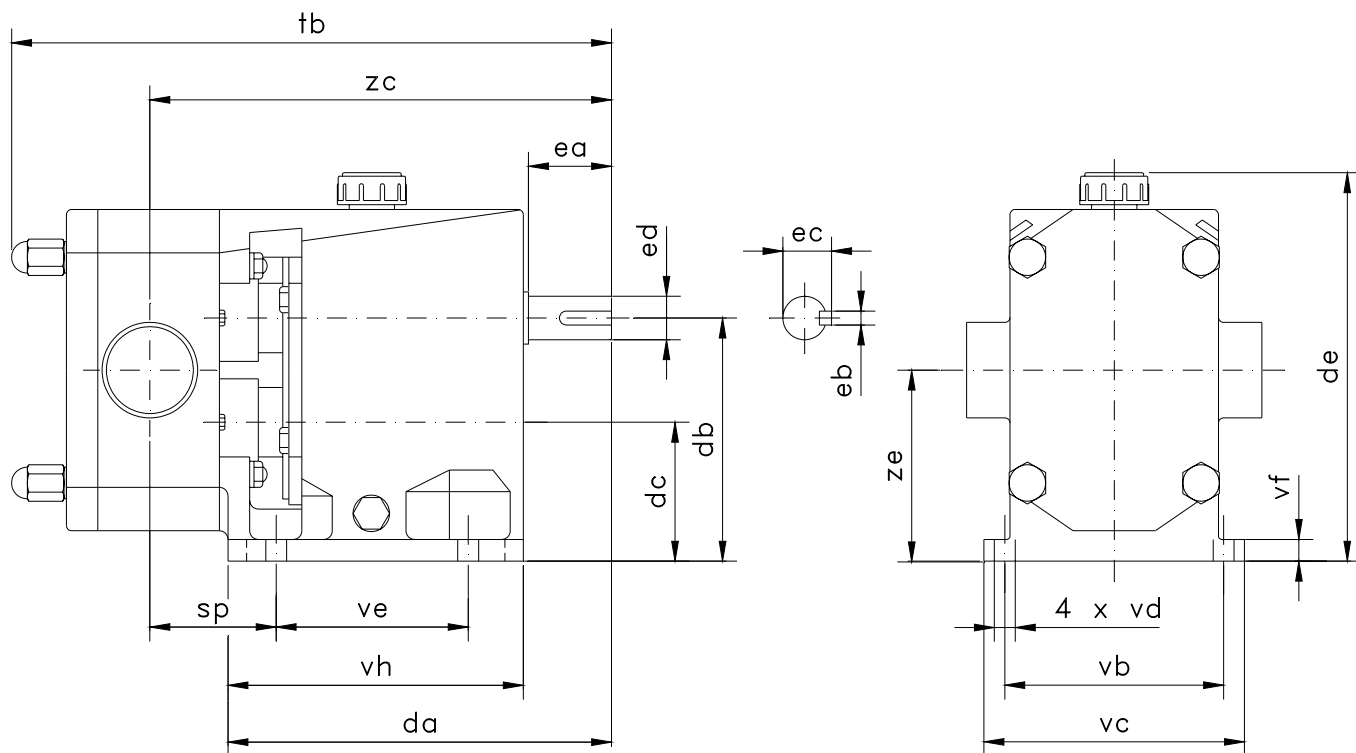

SLR	DN	da	db	dc	de	ea	eb	ec	ed	sp	tb	vb	vc	vd	ve	vf	vh	zc	ze
0-10	10-1/2"	160	80	40	138	30	5	16,2	14	61	253	102	118	9	50	9	65	213	60
0-20	20-3/4"									64	261							216	
0-25	25-1"									68	269							220	
1-20	20-3/4"	187	112	62	186	40	6	21,6	19	67	280	115	135	9	85	10	145	221	87
1-25	25-1"									64	280							218	
1-40	40-1 1/2"									70	292							224	
2-25	25-1"	221	140	78	224	50	8	27	24	80	337	125	150	11	105	12	169	267	109
2-40	40-1 1/2"									74	337							261	
2-50	50-2"									80	349							267	
3-40	40-1 1/2"	297	190	97	289	80	10	41,4	38	97	430	170	210	13	130	14	214	354	143,5
3-50	50-2"									91	430							348	
3-80	80-3"									101	452							360	
4-50	50-2"	433	240	120	366	110	16	58,9	55	117	627	260	290	18	280	15	320	530	180
4-100	100-4"									92	627							505	
4-150	150-6"									117	677							530	
5-125	125-5"	567	350	178	508	140	18	64,3	60	118	793	380	420	18	373	29	423	660	264
5-150	150-6"									130	818							672	

Dimensions SLR 0-1-2-3 (vertical inlets).

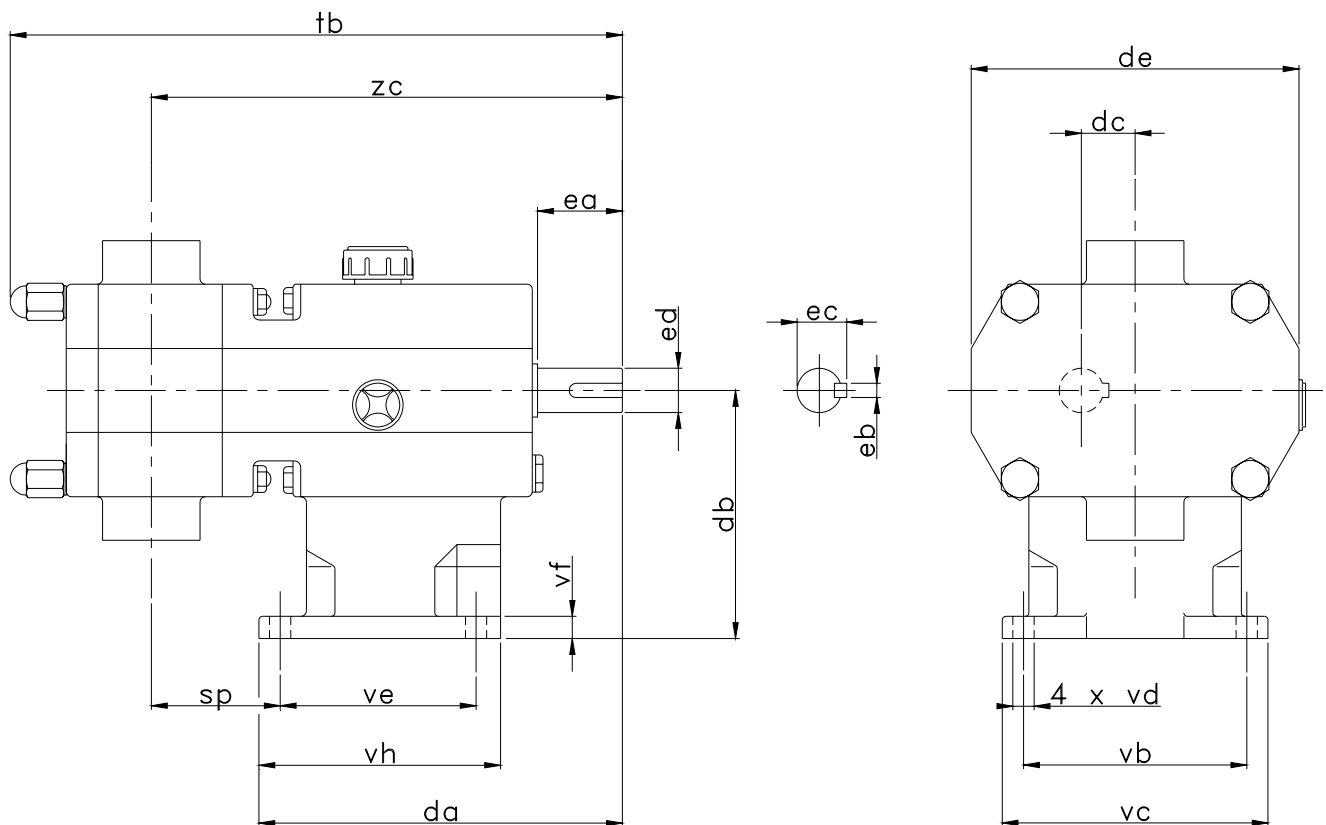

SLR	da	db	dc	de	ea	eb	ec	ed	sp	tb	vb	vc	vd	ve	vf	vh	zc
0-10									61	253							213
0-20	160	80	20	115	30	5	16,2	14	64	261	102	118	9	50	9	65	216
0-25									68	269							220
1-20									67	280							221
1-25	165	112	25	160	40	6	21,6	19	64	280	115	135	9	85	10	105	218
1-40									70	292							224
2-25									80	337							267
2-40	200	140	31	190	50	8	27	24	74	337	125	150	11	105	12	130	261
2-50									80	349							267
3-40									97	430							354
3-50	280	190	46,5	250	80	10	41,4	38	91	430	170	210	13	130	14	170	348
3-80									101	452							360

Dimensions SLR 4 - 5 (vertical inlets).

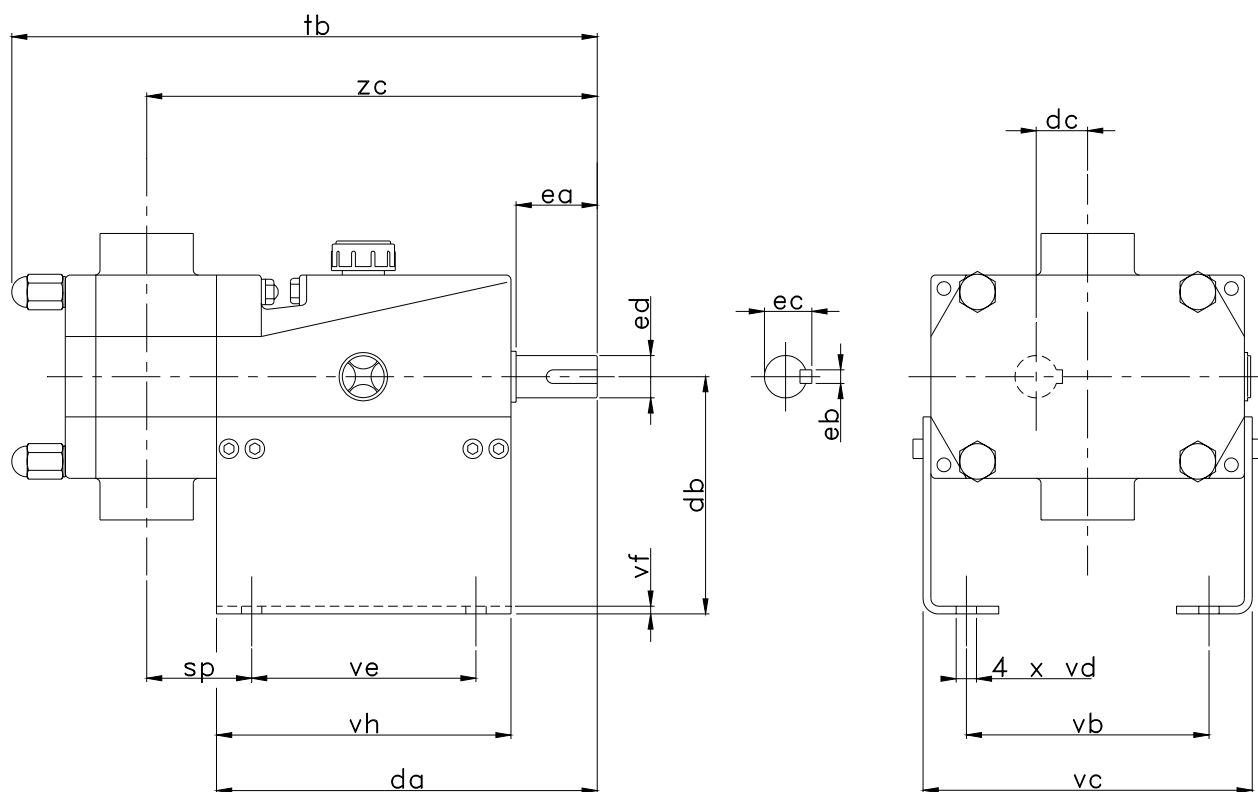

SLR	da	db	dc	ea	eb	ec	ed	sp	tb	vb	vc	vd	ve	vf	vh	zc
4-50	433	225	60	110	16	58,9	55	117	627	260	345	18	280	6	320	530
4-100								92								505
4-150								117	677							530
5-125	567	280	86	140	18	64,3	60	118	793	380	500	18	373	10	423	660
5-150								130								818

Dimensions pump with flushing and/or sealing heating jacket and front heating jacket.

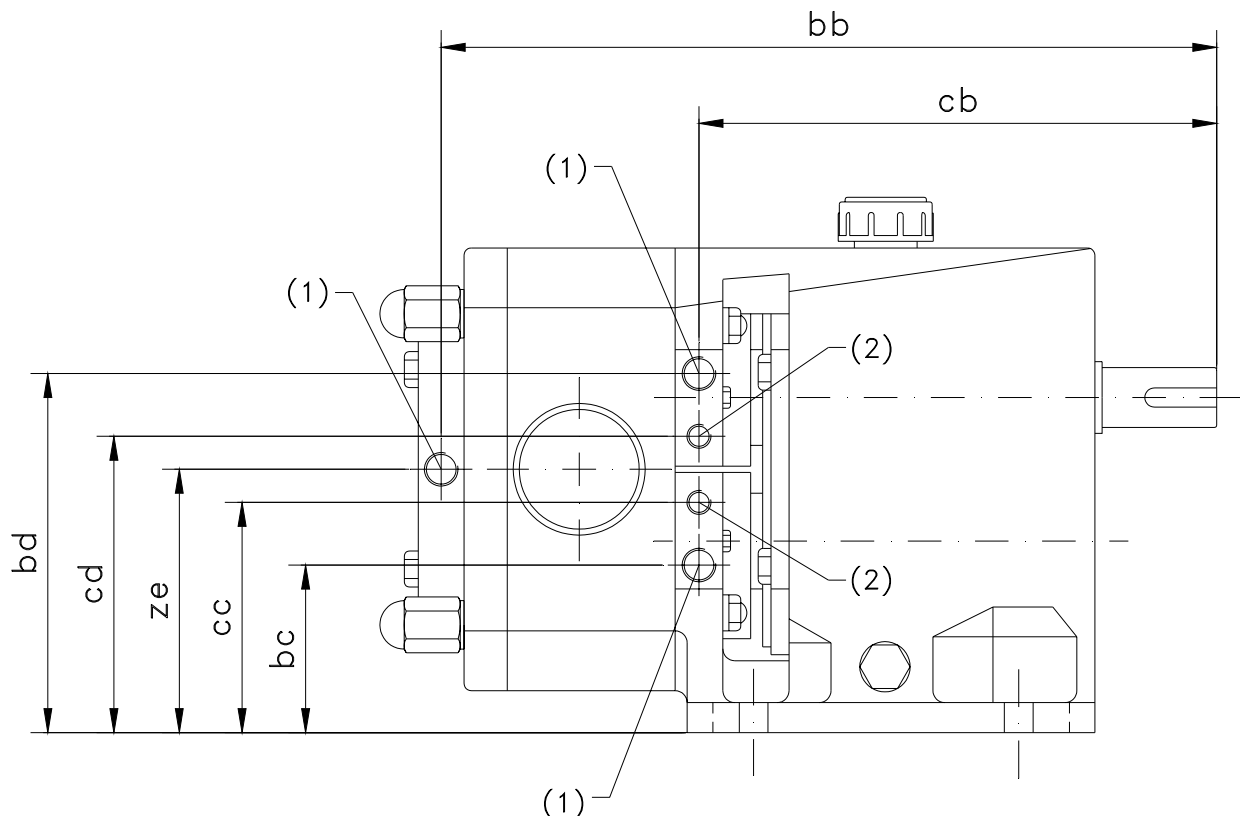

Heating jacket connection 6 x R1/4"
 (SLR 5) 6 x R3/8"
 Flushing sealing connection 4 x R1/8"
 (SLR 5) 4 x R1/4"

SLR	bb	bc	bd	cb	cc	cd	ze
1-25	263	-	-	182	72	102	87
1-40	275	-	-	182	72	102	87
2-25	314	64,5	143,5	216	89	129	109
2-40							
2-50							
3-40	407	82	205	295	112	175	143,5
3-50							
3-80							
4-50	562	107	253	389	150	210	180
4-100							
4-150							
5-125	771	178	350	549	212	316	264
5-150							
	795						

Dimensions pump with safety valve and front heating jacket.

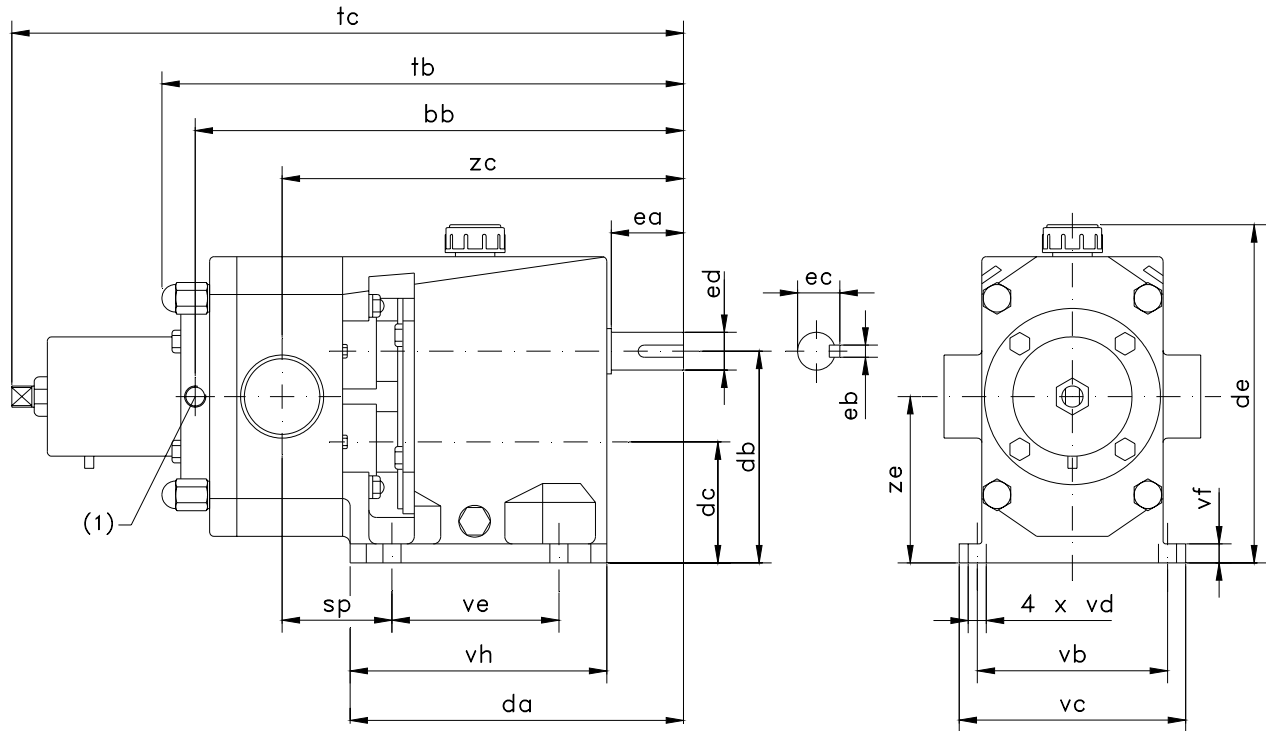

(1) Heating jacket connection 2 x R1/4"
(to SLR 5) 2 x R3/8"

SLR	bb	da	db	dc	de	ea	eb	ec	ed	sp	tb	tc	vb	vc	vd	ve	vf	vh	zc	ze
1-25	263	187	112	62	186	40	6	21,6	19	64	280	366	115	135	9	85	10	145	218	87
1-40	275									70	292	378							267	
2-25	314	221	140	78	224	50	8	27	24	80	337	444	125	150	11	105	12	169	267	109
2-40										74									261	
2-50										326	80	349							456	
3-40	407	297	190	97	289	80	10	41,4	38	97	430	573	170	210	13	130	14	214	354	143,5
3-50										91									348	
3-80										430	101	452							595	
4-50	562	433	240	120	366	110	16	58,9	55	117	627	810	260	290	18	280	15	320	530	180
4-100	92									505										
4-150	612									117	677	860							530	
5-125	771	567	350	178	508	140	18	64,3	60	118	793	1058	380	420	18	373	29	423	660	264
5-150	795									130	818	1082							672	

Dimensions zb.

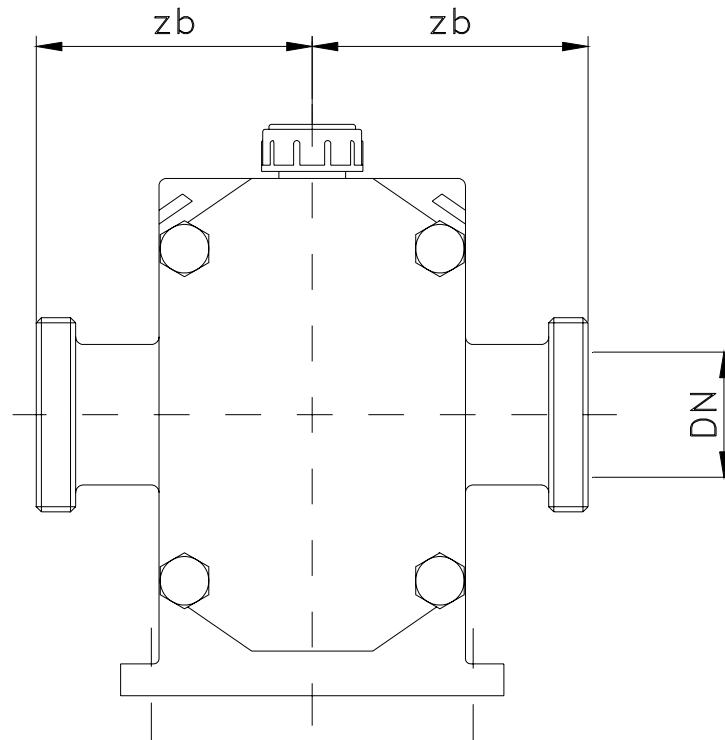

SLR	DN	zb				
		DIN 11851	ISO 2852 "Clamp"	ISO 2853 FIL-IDF	B.S. 1864 RJT	SMS 1145
0-10	10 / ½"	64	63	-	-	-
0-20	20 / ¾"	67		-	-	-
0-25	25 / 1"	72	72	64,5	64,5	62
1-20	20 / ¾"	91,5	106,5	-	-	-
1-25	25 / 1"	94,5	94	94	94	91
1-40	40 / 1½"	99,5	99	99	99	100
2-25	25 / 1"	107	106,5	106,5	106,5	103,5
2-40	40 / 1½"					107,5
2-50	50 / 2"	108	134	134	134	134,5
3-40	40 / 1½"	134				
3-50	50 / 2"	135,5	134	134	134	135
3-80	80 / 3"	137,5				139,5
4-50	50 / 2"	163	161,5	161,5	161,5	162,5
4-100	100 / 4"	170				170
4-150	150 / 6"	180	168	-	-	-
5-125	125 / 5"	225	-	-	-	-
5-150	150 / 6"	230	218	-	-	-

Dimensions flange connections to DIN 2633 PN 16 and DIN 2634 PN 25.

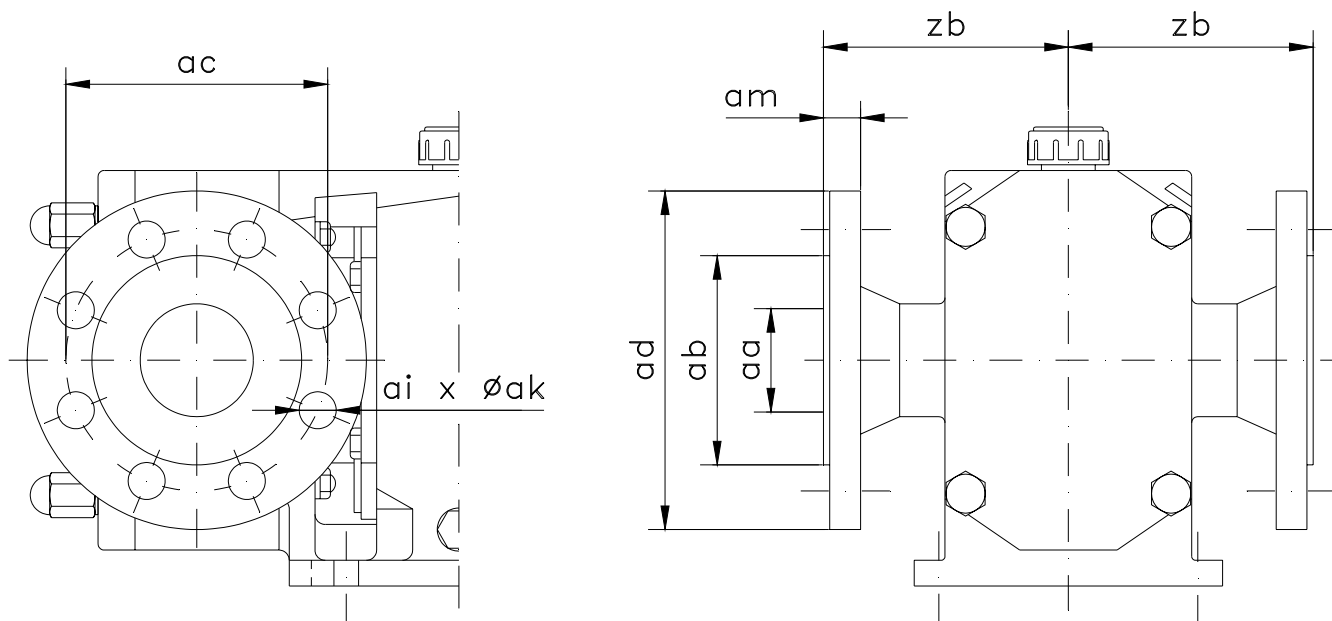

SLR	DIN 2633 PN 16						
	aa	ab	ac	ad	ai x ϕ ak	am	zb
1-20	20	58	75	105	4 x 14	16	110,5
1-25	25	68	85	115			107
1-40	40	88	110	150			119,5
2-25	25	68	85	115	4 x 14	16	120
2-40	40	88	110	150	4 x 18		127
2-50	50	102	125	165	4 x 18	18	130
3-40	40	88	110	150	4 x 18	16	154
3-50	50	102	125	165		18	157,5
3-80	80	138	160	200		8 x 18	20
4-50	50	102	125	165	4 x 18	18	185
4-100	100	158	180	220	8 x 18	20	192
4-150	150	212	240	285	8 x 23	22	195
5-125	125	188	210	250	8 x 18		245
5-150	150	212	240	285	8 x 23		
DIN 2634 PN 25							
1-20	20	58	75	105	4 x 14	18	112,5
2-25	25	68	85	115	4 x 14	18	120
3-40	40	88	110	150	4 x 18	18	157
4-50	50	102	125	165	4 x 18	20	188

Dimensions rectangular inlet.

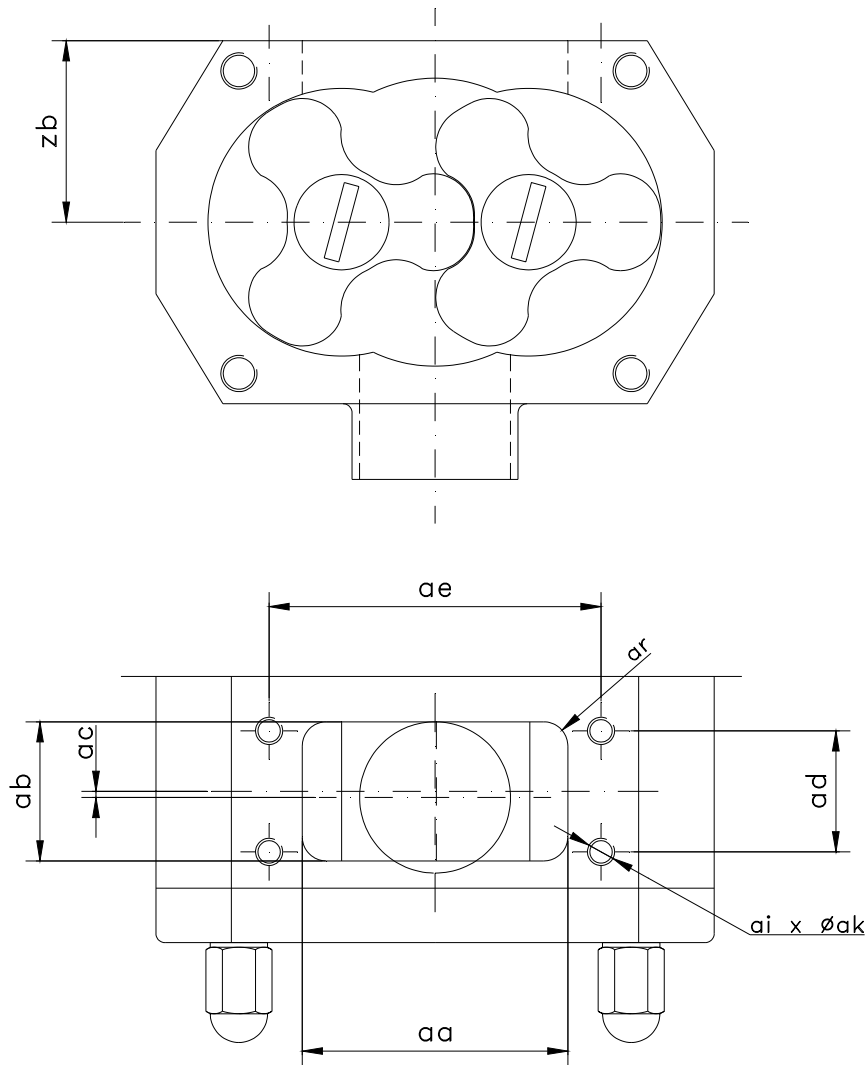

SLR	aa	ab	ac	ad	ae	ar	ai x ϕ ak	zb
2-50	86	46	2	40	108	10	4 x M8	60
3-80	145	66	3	50	170	12,5	4 x M10	87,5
4-150	190	140	5	120	230	15	4 x M12	110
5-150	210	130	10		250			160

Hyduty SLR 0-10.

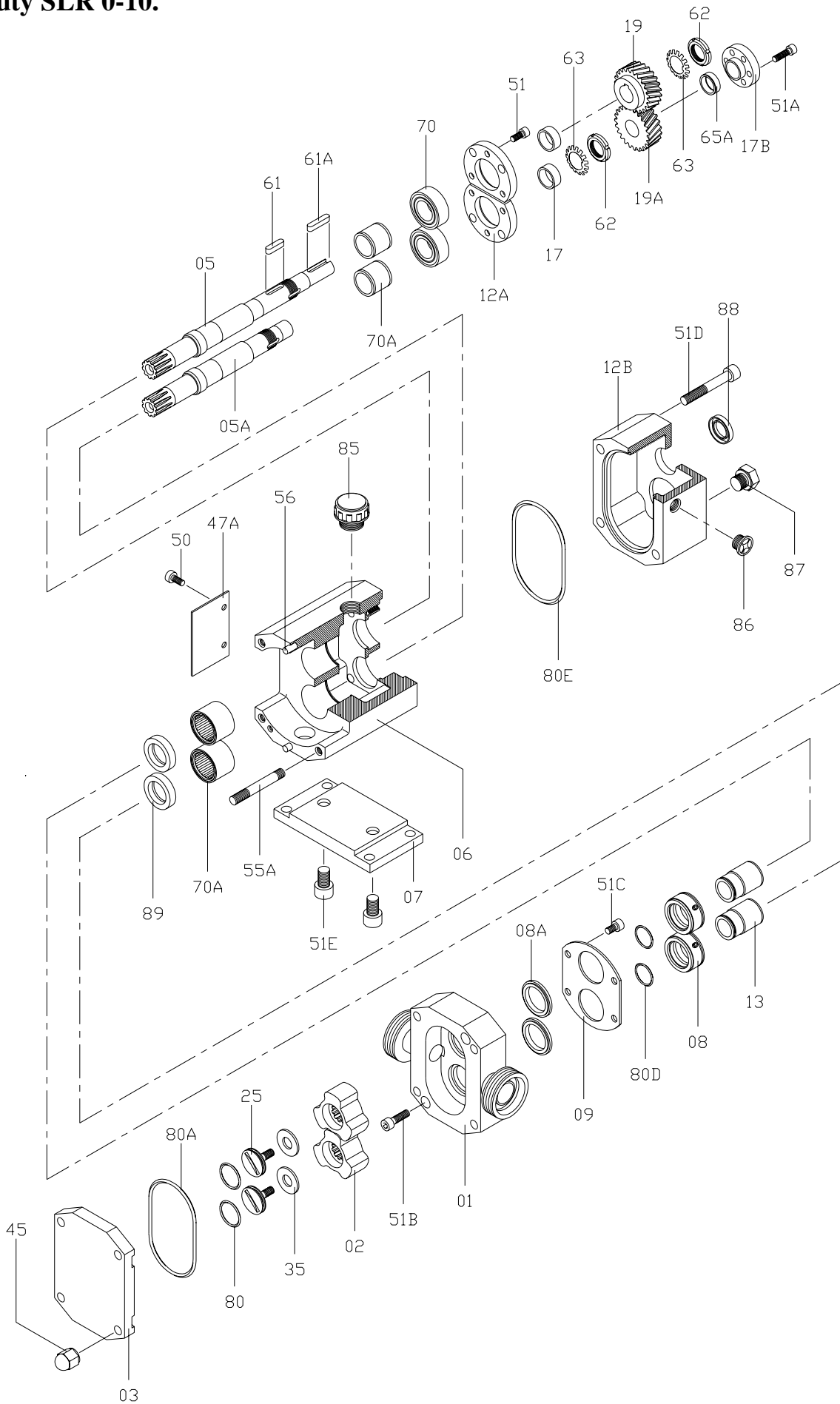

Parts list Hyduty SLR 0-10.

Position	Quantity	Description	Material
01	1	Pump housing	CF-8M
02	2	Trilobe	AISI-316
03	1	Pump cover	AISI-316
05	1	Drive shaft	AISI-329
05A	1	Driven shaft	AISI-329
06	1	Support	GG-15
07	1	Leg	F-114
12A	2	Bearing cover	F-114
12B	1	Back cover	GG-15
17	2	Drive shaft bushing	F-114
17B	1	Dragging bushing	F-114
19	1	Drive shaft gear	F-154
19A	1	Driven shaft gear	F-154
25	2	Lobe screw	AISI-316
45	4	Wing nut	AISI-304
47A	4	Protector	Plastic
50	4	Screw	A2
51	6	Allen screw	8.8
51A	6	Allen screw	8.8
51B	2	Allen screw	A2
51D	4	Allen screw	8.8
51E	2	Allen screw	8.8
55A	4	Stud	A2
56	2	Pin	F-522
61	1	Key	F-114
61A	1	Key	AISI-304
62	2	Safety nut	Steel
63	2	Safety washer	Steel
65A	1	Conical tightening ring	Steel
70	2	Ball bearings	Steel
70A	2	Needle bearings	Steel
80	2	O-ring	EPDM
80A	1	O-ring	EPDM
80D	2	O-ring	EPDM
80E	1	O-ring	NBR
85	1	Oil plug	Plastic
86	1	Peephole	Plastic
87	1	Bleeder	Plastic
88	1	Lip seal	NBR
89	2	Lip seal	NBR

Hyclean SLR 0-20 / 0-25.

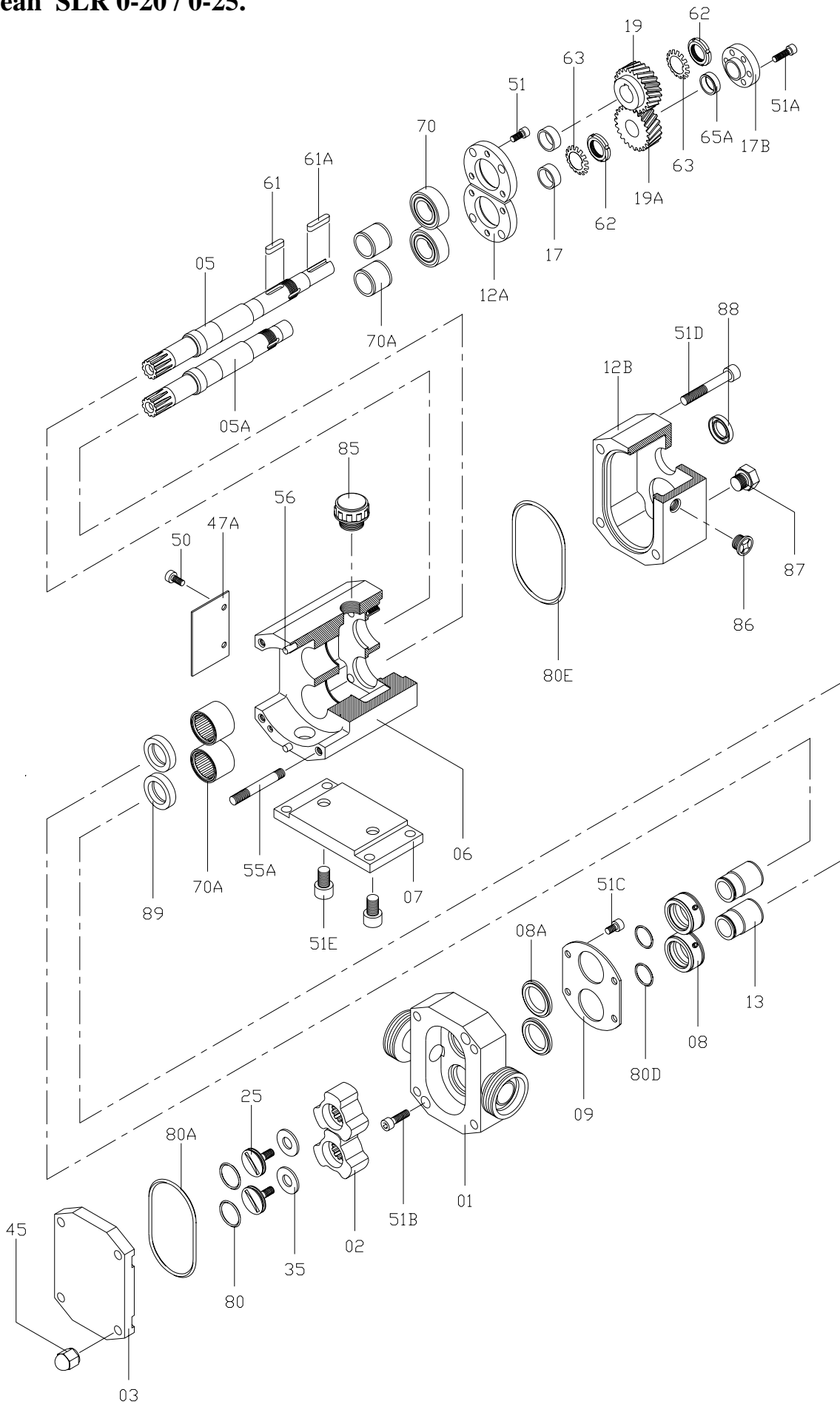

Parts list Hyclean SLR 0-20 / 0-25.

Position	Quantity	Description	Material
01	1	Pump housing	CF-8M
02	2	Trilobe	AISI-316
03	1	Pump cover	AISI-316
05	1	Drive shaft	AISI-329
05A	1	Driven shaft	AISI-329
06	1	Support	GG-15
07	1	Leg	F-114
12A	2	Bearing cover	F-114
12B	1	Back cover	GG-15
17	2	Drive shaft bushing	F-114
17B	1	Dragging bushing	F-114
19	1	Drive shaft gear	F-154
19A	1	Driven shaft gear	F-154
25	2	Lobe screw	AISI-316
35	2	Lobe washer	AISI-316
45	4	Wing nut	AISI-304
47A	4	Protector	Plastic
50	4	Screw	A2
51	6	Allen screw	8.8
51A	6	Allen screw	8.8
51B	2	Allen screw	A2
51D	4	Allen screw	8.8
51E	2	Allen screw	8.8
55A	4	Stud	A2
56	2	Pin	F-522
61	1	Key	F-114
61A	1	Key	AISI-304
62	2	Safety nut	Steel
63	2	Safety washer	Steel
65A	1	Conical tightening ring	Steel
70	2	Ball bearings	Steel
70A	2	Needle bearings	Steel
80	2	O-ring	EPDM
80A	1	O-ring	EPDM
80D	2	O-ring	EPDM
80E	1	O-ring	NBR
85	1	Oil plug	Plastic
86	1	Peephole	Plastic
87	1	Bleeder	Plastic
88	1	Lip seal	NBR
89	2	Lip seal	NBR

Hyduty SLR 1-20.

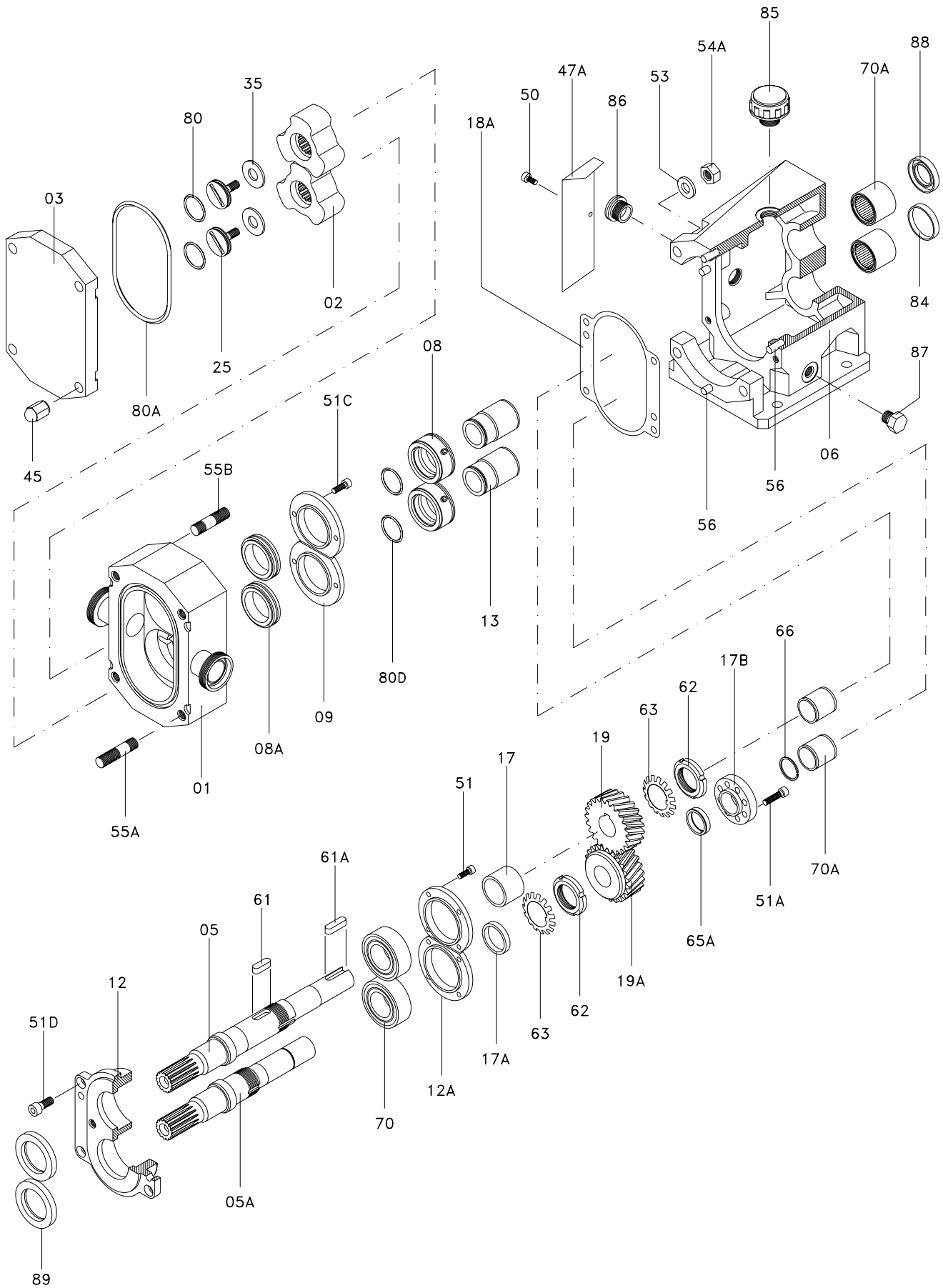

Parts list Hyduty SLR 1-20.

Position	Quantity	Description	Material
01	1	Pump housing	CF-8M
02	2	Trilobe	AISI-316
03	1	Pump cover	AISI-316
05	1	Drive shaft	AISI-329
05A	1	Driven shaft	AISI-329
06	1	Support	GG-15
12	1	Bearing cover	GG-15
12A	2	Bearing stop flange	F-114
17	1	Drive shaft bushing	ST-35
17A	1	Driven shaft bushing	ST-35
17B	1	Dragging bushing	F-114
18A	1	Gasket	Klingerit
19	1	Drive shaft gear	F-154
19A	1	Driven shaft gear	F-154
25	2	Lobe screw	AISI-316
35	2	Lobe washer	AISI-316
45	4	Wing-nut	AISI-316
47A	4	Protector	Plastic
50	2	Screw	A2
51	8	Allen screw	8.8
51A	8	Allen screw	8.8
51D	4	Allen screw	8.8
53	4	Flat washer	A2
54A	4	Hexagonal nut	A4
55A	4	Stud	A2
55B	4	Stud	A2
56	4	Pin	F-522
61	1	Key	F-114
61A	1	Key	AISI-304
62	2	Safety nut	Steel
63	2	Safety washer	Steel
65A	1	Conical tightening ring	Steel
66	1	Elastic ring	Steel
70	2	Ball bearings	Steel
70A	2	Needle bearings	Steel
80	2	O-ring	EPDM
80A	1	O-ring	EPDM
80D	2	O-ring	EPDM
84	1	Blanking plug	NBR
85	1	Oil plug	Plastic
86	1	Peephole	Plastic
87	1	Bleeder	Plastic
88	1	Lip seal	NBR
89	2	Lip seal	NBR

Hyclean SLR 1-25 / 1-40.

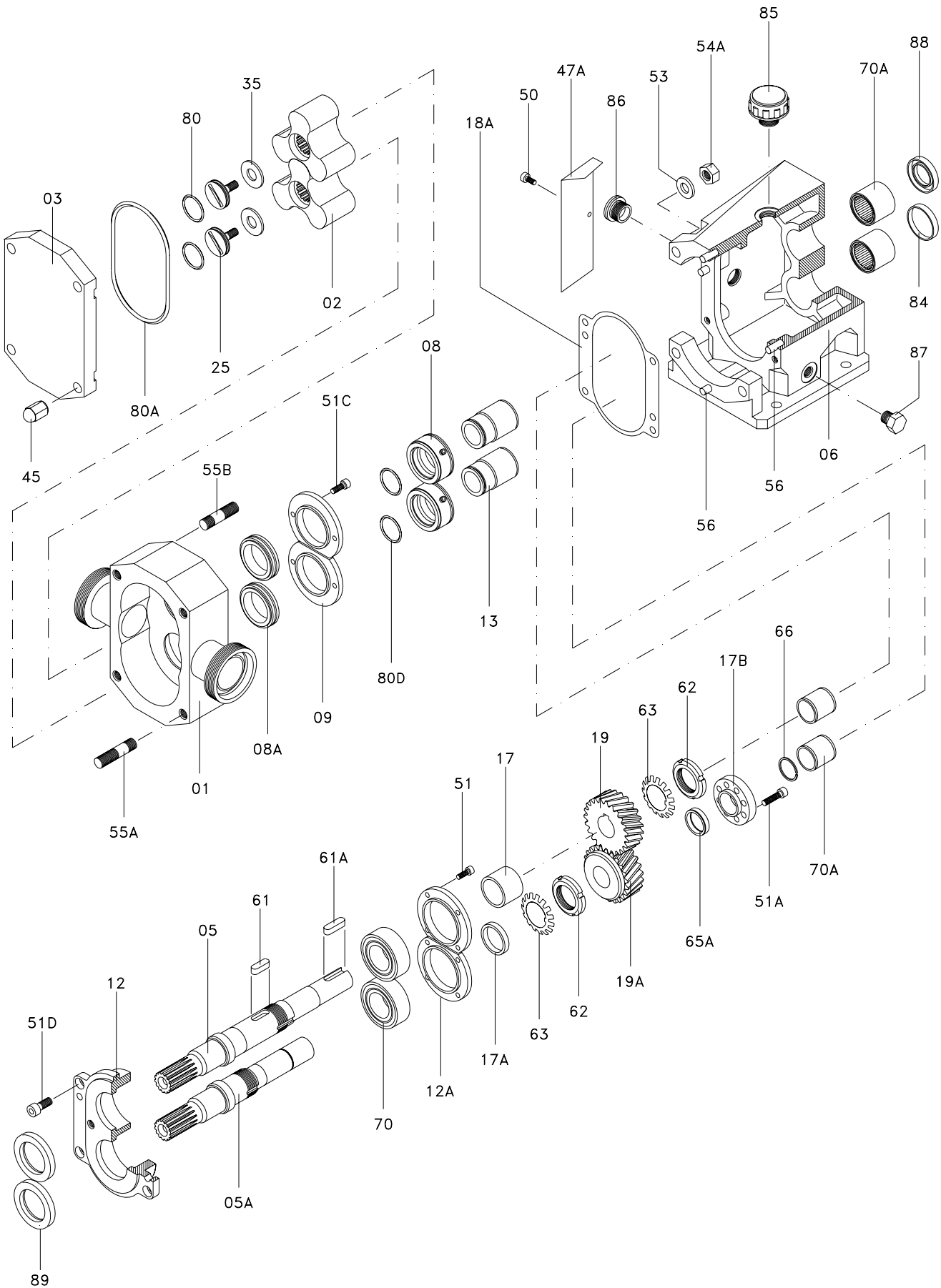

Parts list Hyclean SLR 1-25 / 1-40.

Position	Quantity	Description	Material
01	1	Pump housing	CF-8M
02	2	Trilobe	AISI-316
03	1	Pump cover	AISI-316
05	1	Drive shaft	AISI-329
05A	1	Driven shaft	AISI-329
06	1	Support	GG-15
12	1	Bearing cover	GG-15
12A	2	Bearing stop flange	F-114
17	1	Drive shaft bushing	ST-35
17A	1	Driven shaft bushing	ST-35
17B	1	Dragging bushing	F-114
18A	1	Gasket	Klingerit
19	1	Drive shaft gear	F-154
19A	1	Driven shaft gear	F-154
25	2	Lobe screw	AISI-316
35	2	Lobe washer	AISI-316
45	4	Wing-nut	AISI-316
47A	4	Protector	Plastic
50	2	Screw	A2
51	8	Allen screw	8.8
51A	8	Allen screw	8.8
51D	4	Allen screw	8.8
53	4	Flat washer	A2
54A	4	Hexagonal nut	A4
55A	4	Stud	A2
55B	4	Stud	A2
56	4	Pin	F-522
61	1	Key	F-114
61A	1	Key	AISI-304
62	2	Safety nut	Steel
63	2	Safety washer	Steel
65A	1	Conical tightening ring	Steel
66	1	Elastic ring	Steel
70	2	Ball bearings	Steel
70A	2	Needle bearings	Steel
80	2	O-ring	EPDM
80A	1	O-ring	EPDM
80D	2	O-ring	EPDM
84	1	Blanking plug	NBR
85	1	Oil plug	Plastic
86	1	Peephole	Plastic
87	1	Bleeder	Plastic
88	1	Lip seal	NBR
89	2	Lip seal	NBR

Hyduty SLR 2 - 25.

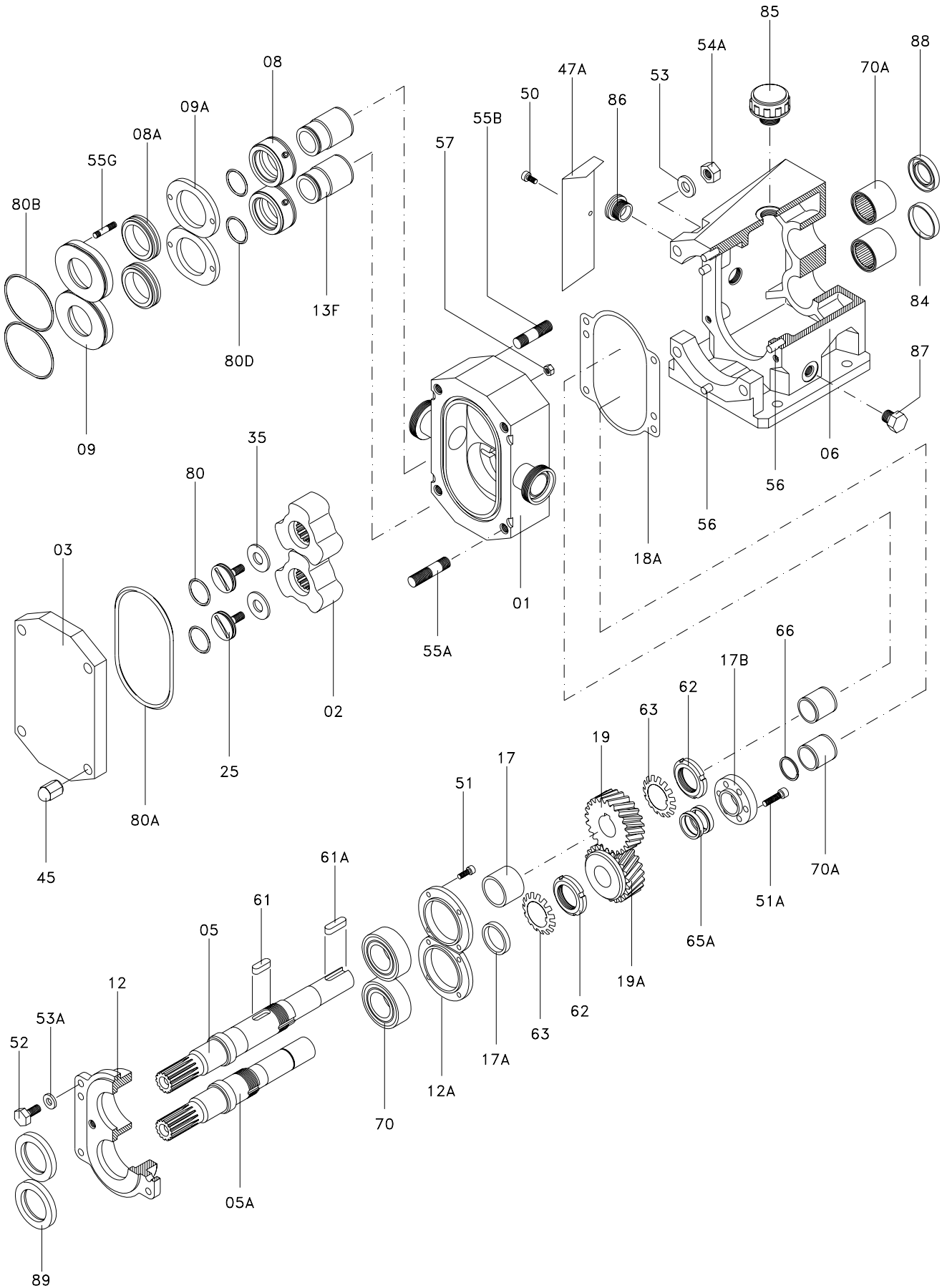

Part list Hyduty SLR 2 - 25.

Position	Quantity	Description	Material
01	1	Pump housing	CF-8M
02	2	Trilobe	AISI-316
03	1	Pump cover	AISI-316
05	1	Drive shaft	AISI-316
05A	1	Driven shaft	AISI-329
06	1	Support	GG-15
12	1	Bearing cover	GG-15
12A	2	Bearing stop flange	GG-15
17	1	Drive shaft bushing	ST-35
17A	1	Driven shaft bushing	ST-35
17B	1	Dragging bushing	F-114
18A	1	Gasket	Klingerit
19	1	Drive shaft gear	F-154
19A	1	Driven shaft gear	F-154
25	2	Lobe screw	AISI-316
35	2	Lobe washer	AISI-316
45	4	Wing nut	AISI-316
47A	4	Protector	Plastic
50	2	Screw	A2
51	8	Allen screw	8.8
51A	6	Allen screw	8.8
52	4	Hexagonal screw	8.8
53	4	Flat washer	A2
53A	4	Spring washer	8.8
54A	4	Hexagonal nut	A4
55A	4	Stud	A2
55B	4	Stud	A2
56	4	Pin	F-522
61	1	Key	F-114
61A	1	Key	AISI-304
62	2	Safety nut	Steel
63	2	Safety washer	Steel
65A	2	Conical tightening ring	Steel
66	1	Elastic ring	Steel
70	2	Ball bearings	Steel
70A	2	Needle bearings	Steel
80	2	O-ring	EPDM
80A	1	O-ring	EPDM
80D	2	O-ring	EPDM
84	1	Blanking plug	NBR
85	1	Oil plug	Plastic
86	1	Peephole	Plastic
87	1	Bleeder	Plastic
88	1	Lip seal	NBR
89	2	Lip seal	NBR

Hyclean SLR 2-40 / 2-50.

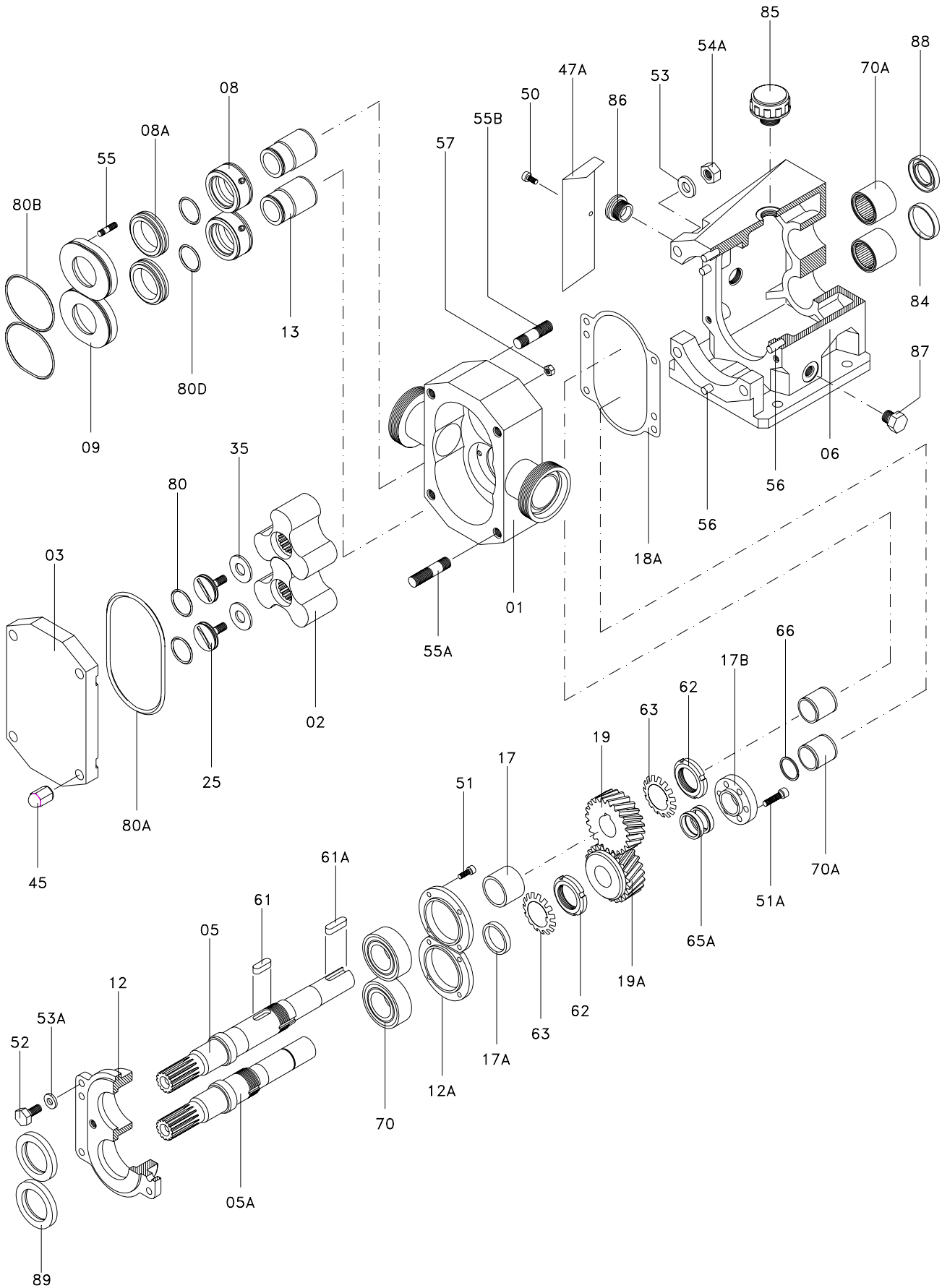

Parts list Hyclean SLR 2-40 / 2-50.

Position	Quantity	Description	Material
01	1	Pump housing	CF-8M
02	2	Trilobe	AISI-316
03	1	Pump cover	AISI-316
05	1	Drive shaft	AISI-316
05A	1	Driven shaft	AISI-329
06	1	Support	GG-15
12	1	Bearing cover	GG-15
12A	2	Bearing stop flange	GG-15
17	1	Drive shaft bushing	ST-35
17A	1	Driven shaft bushing	ST-35
17B	1	Dragging bushing	F-114
18A	1	Gasket	Klingerit
19	1	Drive shaft gear	F-154
19A	1	Driven shaft gear	F-154
25	2	Lobe screw	AISI-316
35	2	Lobe washer	AISI-316
45	4	Wing-nut	AISI-316
47A	4	Protector	Plastic
50	2	Screw	A2
51	8	Allen screw	8.8
51A	6	Allen screw	8.8
52	4	Hexagonal screw	8.8
53	4	Flat washer	A2
53A	4	Spring washer	Steel
54A	4	Hexagonal nut	A4
55A	4	Stud	A2
55B	4	Stud	A2
56	4	Pin	F-522
61	1	Key	F-114
61A	1	Key	AISI-304
62	2	Safety nut	Steel
63	2	Safety washer	Steel
65A	2	Conical tightening ring	Steel
66	1	Elastic ring	Steel
70	2	Ball bearings	Steel
70A	2	Needle bearings	Steel
80	2	O-ring	EPDM
80A	1	O-ring	EPDM
80D	2	O-ring	EPDM
84	1	Blanking plug	NBR
85	1	Oil plug	Plastic
86	1	Peephole	Plastic
87	1	Bleeder	Plastic
88	1	Lip seal	NBR
89	2	Lip seal	NBR

Hyduty SLR 3-40.

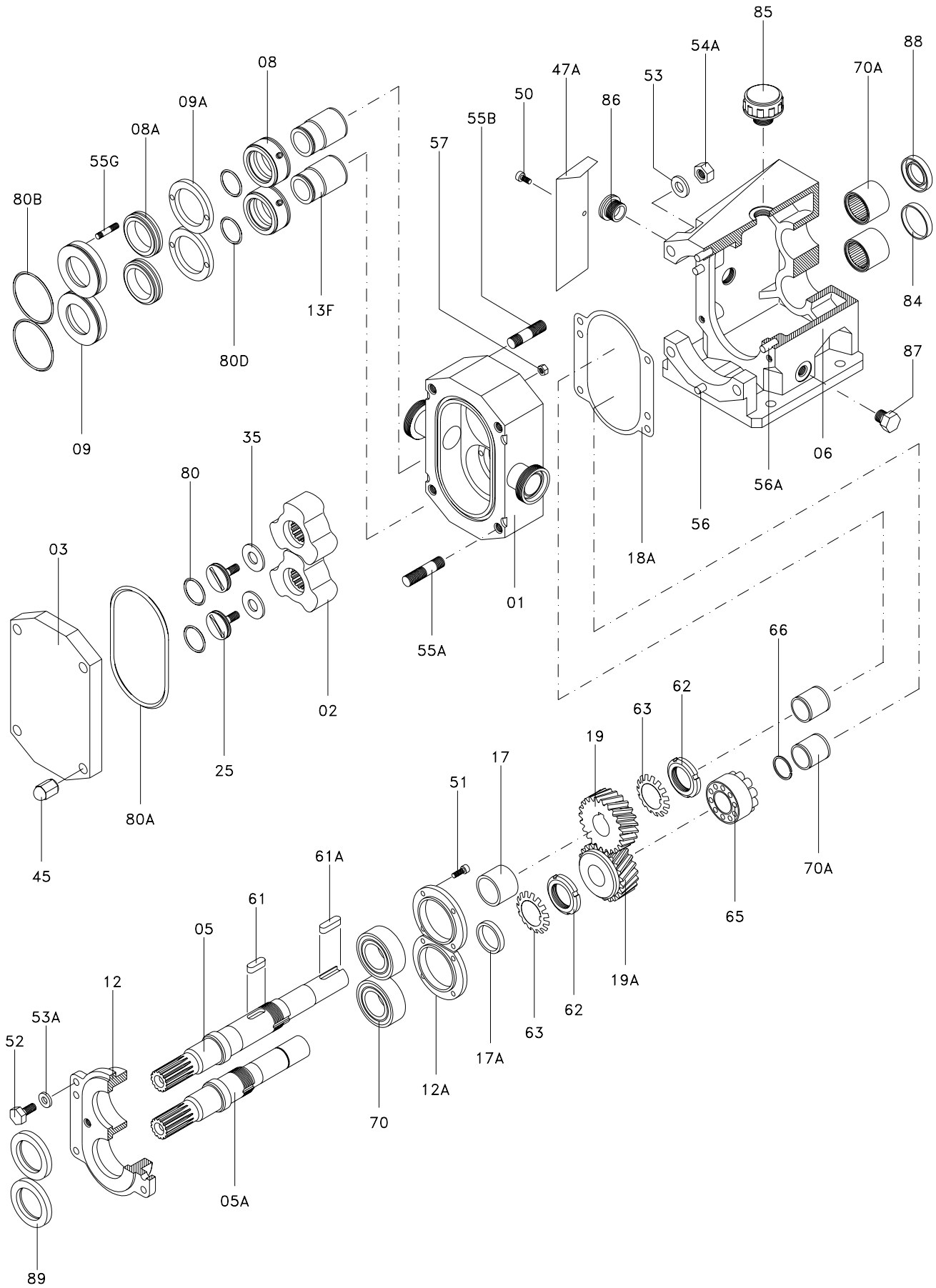

Parts list Hyduty SLR 3-40.

Position	Quantity	Description	Material
01	1	Pump housing	CF-8M
02	2	Trilobe	AISI-316
03	1	Pump cover	AISI-316
05	1	Drive shaft	AISI-329
05A	1	Driven shaft	AISI-329
06	1	Support	GG-15
12	1	Bearing cover	GG-15
12A	2	Bearing stop flange	GG-15
17	1	Drive shaft bushing	ST-52
17A	1	Driven shaft bushing	ST-52
18A	1	Dragging bushing	Klingerit
19	1	Drive shaft gear	F-154
19A	1	Driven shaft gear	F-154
25	2	Lobe screw	AISI-316
35	2	Lobe washer	AISI-316
45	4	Wing nut	AISI-316
47A	4	Protector	Plastic
50	2	Screw	A2
51	8	Allen screw	8.8
52	4	Hexagonal screw	8.8
53	4	Flat washer	A2
53A	4	Spring washer	8.8
54A	4	Hexagonal nut	A4
55A	8	Stud	A2
56	2	Pin	F-522
56A	2	Pin	F-522
61	1	Key	F-114
61A	1	Key	AISI-304
62	2	Safety nut	Steel
63	2	Safety washer	Steel
65	1	Conical tightening ring	Steel
66	1	Elastic ring	Steel
70	2	Ball bearings	Steel
70A	2	Needle bearings	Steel
80	2	O-ring	EPDM
80A	1	O-ring	EPDM
80D	2	O-ring	EPDM
84	1	Blanking plug	NBR
85	1	Oil plug	Plastic
86	1	Peephole	Plastic
87	1	Bleeder	Plastic
88	1	Lip seal	NBR
89	2	Lip seal	NBR

Hyclean SLR 3-50 / 3-80.

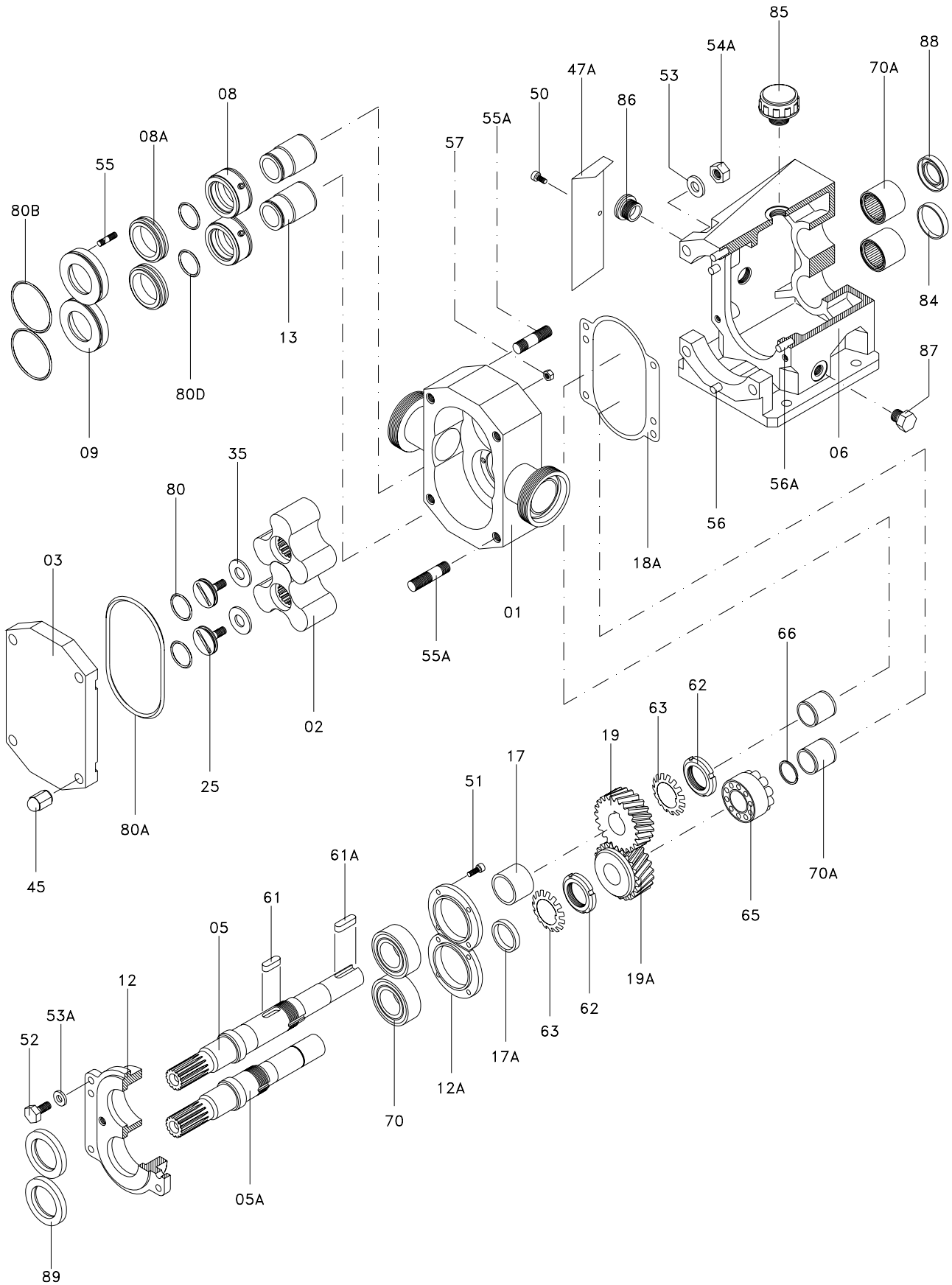

Parts list Hyclean SLR 3-50 / 3-80.

Position	Quantity	Description	Material
01	1	Pump housing	CF-8M
02	2	Trilobe	CF-8M
03	1	Pump cover	AISI-316
05	1	Drive shaft	AISI-329
05A	1	Driven shaft	AISI-329
06	1	Support	GG-15
12	1	Bearing cover	GG-15
12A	2	Bearing stop flange	GG-15
17	1	Drive shaft bushing	ST-52
17A	1	Driven shaft bushing	ST-52
18A	1	Dragging bushing	Klingerit
19	1	Drive shaft gear	F-154
19A	1	Driven shaft gear	F-154
25	2	Lobe screw	AISI-316
35	2	Lobe washer	AISI-316
45	4	Wing nut	AISI-316
47A	4	Protector	Plastic
50	2	Screw	A2
51	8	Allen screw	8.8
52	4	Hexagonal screw	8.8
53	4	Flat washer	A2
53A	4	Spring washer	8.8
54A	4	Hexagonal nut	A4
55A	8	Stud	A2
56	2	Pin	F-522
56A	2	Pin	F-522
61	1	Key	F-114
61A	1	Key	AISI-304
62	2	Safety nut	Steel
63	2	Safety washer	Steel
65	1	Conical tightening ring	Steel
66	1	Elastic ring	Steel
70	2	Ball bearings	Steel
70A	2	Needle bearings	Steel
80	2	O-ring	EPDM
80A	1	O-ring	EPDM
80D	2	O-ring	EPDM
84	1	Blanking plug	NBR
85	1	Oil plug	Plastic
86	1	Peephole	Plastic
87	1	Bleeder	Plastic
88	1	Lip seal	NBR
89	2	Lip seal	NBR

Hyduty SLR 4-50.

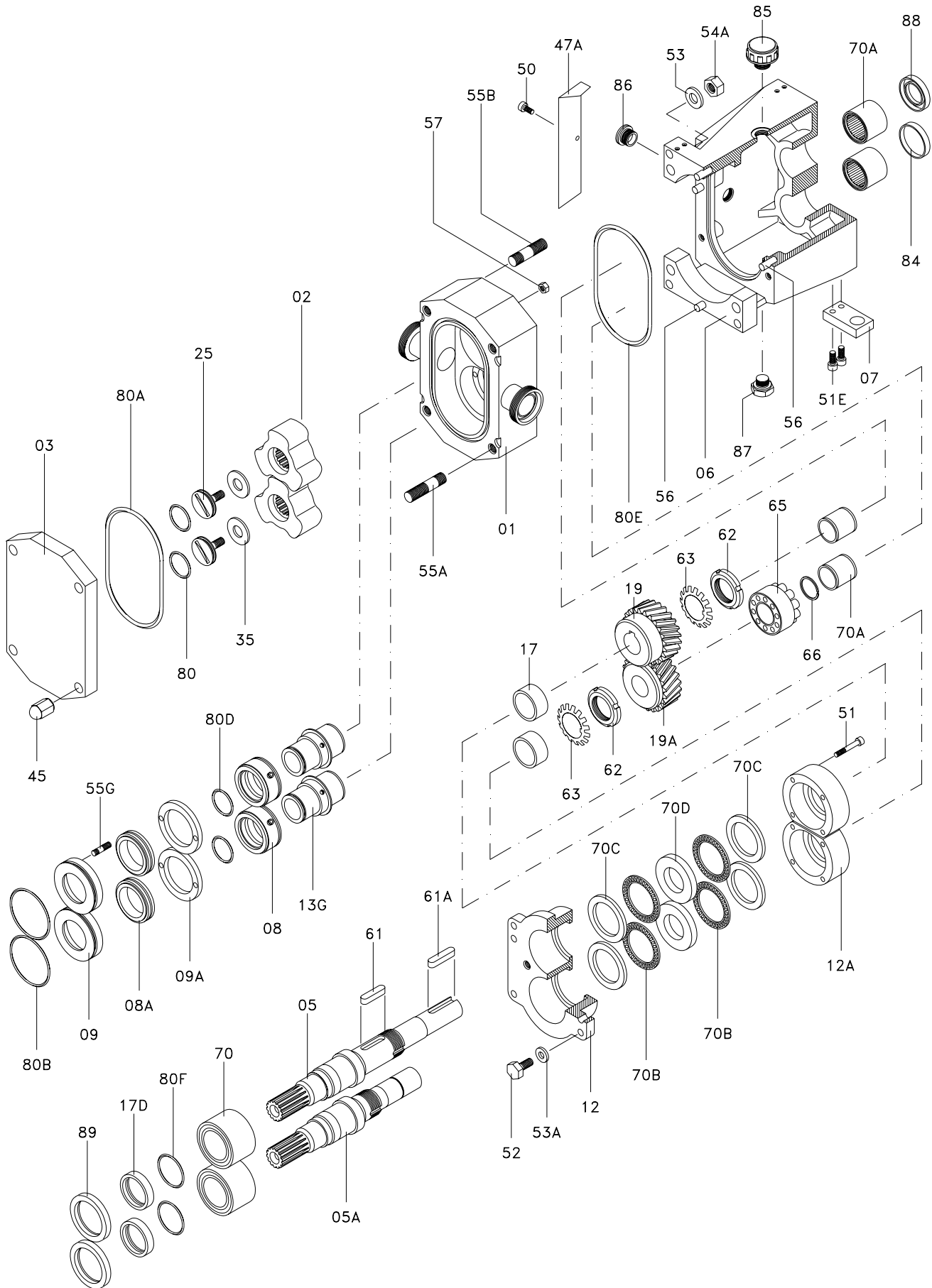

Parts list Hyduty SLR 4-50.

Position	Quantity	Description	Material
01	1	Pump housing	CF-8M
02	2	Trilobe	AISI-316
03	1	Pump cover	AISI-316
05	1	Drive shaft	AISI-329
05A	1	Driven shaft	AISI-329
06	1	Support	GG-15
07	4	Leg	AISI-304
12	1	Bearing cover	GG-15
12A	2	Bearing stop flange	GG-15
17	2	Drive shaft bushing	ST-52
17D	2	Driven shaft bushing	AISI-304
19	1	Drive shaft gear	F-154
19A	1	Driven shaft gear	F-154
25	2	Lobe screw	AISI-316
35	2	Lobe washer	AISI-316
45	4	Wing nut	AISI-316
47A	4	Protector	Plastic
50	2	Screw	A2
51	8	Allen screw	A2
51E	8	Allen screw	8.8
52	4	Hexagonal screw	8.8
53	4	Flatter washer	A2
53A	4	Spring washer	8.8
54A	4	Hexagonal nut	A4
55A	4	Stud	A2
55B	4	Stud	A2
56	4	Pin	F-522
61	1	Key	Steel
61A	1	Key	AISI-304
62	2	Safety nut	Steel
63	2	Safety washer	Steel
65	1	Conical tightening ring	Steel
66	1	Elastic ring	Steel
70	2	Ball bearings	Steel
70A	2	Needle bearings	Steel
70B	4	Axial bearing	Steel
70C	4	Axial disc	Steel
70D	2	Intermediate disc	Steel
80	2	O-ring	EPDM
80A	1	O-ring	EPDM
80D	2	O-ring	EPDM
80E	1	O-ring	EPDM
80F	2	O-ring	EPDM
84	1	Blanking plug	NBR
85	1	Oil plug	Plastic
86	1	Peephole	Plastic
87	1	Bleeder	Plastic
88	1	Lip seal	NBR
89	2	Lip seal	NBR

Hyclean SLR 4-100 / 4-150.

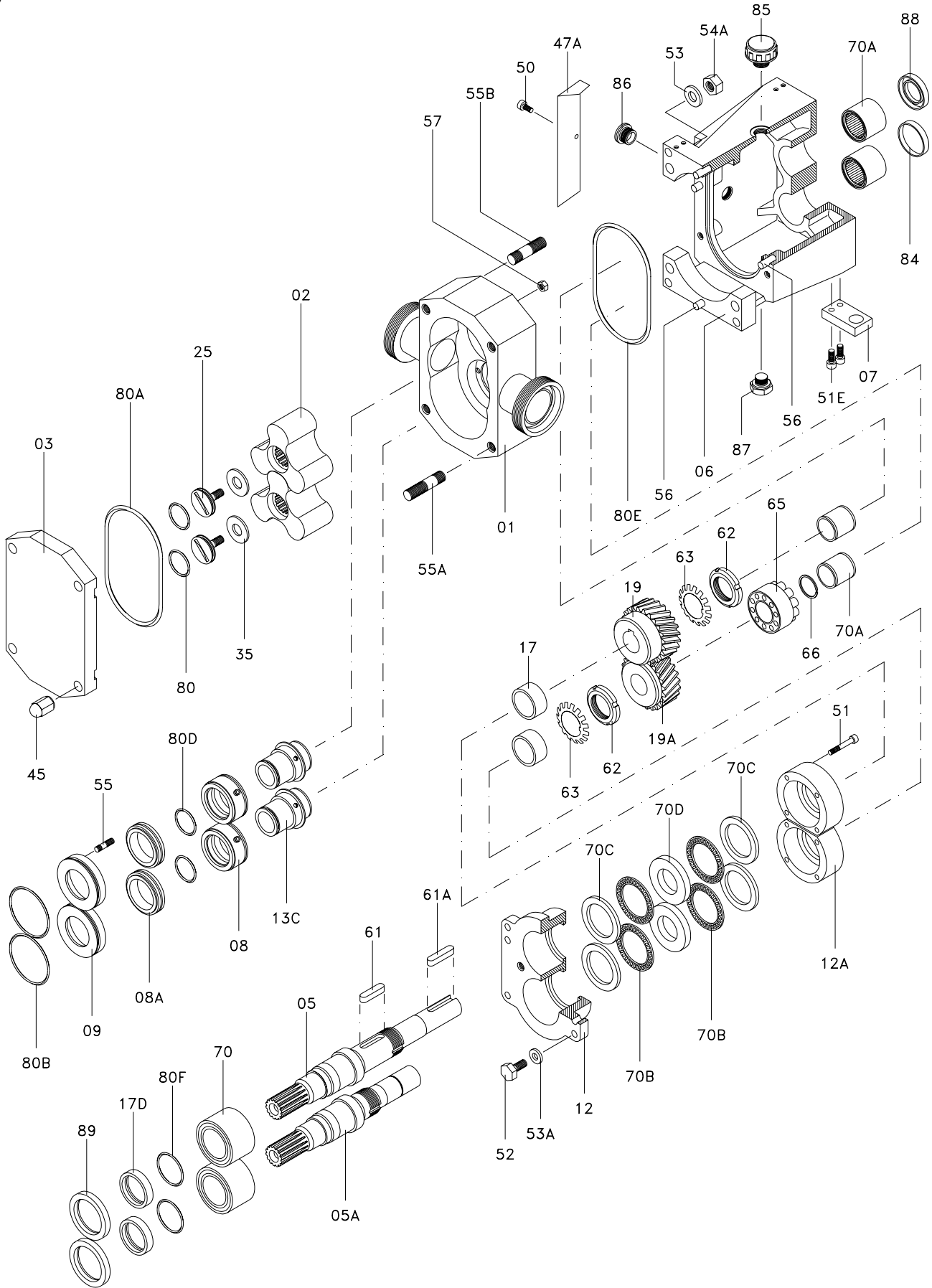

Parts list Hyclean SLR 4-100 / 4-150.

Position	Quantity	Description	Material
01	1	Pump housing	CF-8M
02	2	Trilobe	AISI-316
03	1	Pump cover	AISI-316
05	1	Drive shaft	AISI-329
05A	1	Driven shaft	AISI-329
06	1	Support	GG-15
07	4	Leg	AISI-304
12	1	Bearing cover	GG-15
12A	2	Bearing stop flange	GG-15
17	2	Drive shaft bushing	ST-52
17D	2	Driven shaft bushing	AISI-304
19	1	Drive shaft gear	F-154
19A	1	Driven shaft gear	F-154
25	2	Lobe screw	AISI-316
35	2	Lobe washer	AISI-316
45	4	Wing nut	AISI-316
47A	4	Protector	Plastic
50	2	Screw	A2
51	8	Allen screw	A2
51E	8	Allen screw	8.8
52	4	Hexagonal screw	8.8
53	4	Flat washer	A2
53A	4	Spring washer	8.8
54A	4	Hexagonal nut	A4
55A	4	Stud	A2
55B	4	Stud	A2
56	4	Pin	F-522
61	1	Key	Steel
61A	1	Key	AISI-304
62	2	Safety nut	Steel
63	2	Safety washer	Steel
65	1	Conical tightening ring	Steel
66	1	Elastic ring	Steel
70	2	Ball bearings	Steel
70A	2	Needle bearings	Steel
70B	4	Axial bearing	Steel
70C	4	Axial disc	Steel
70D	2	Intermediate disc	Steel
80	2	O-ring	EPDM
80A	1	O-ring	EPDM
80D	2	O-ring	EPDM
80E	1	O-ring	EPDM
80F	2	O-ring	EPDM
84	1	Blanking plug	NBR
85	1	Oil plug	Plastic
86	1	Peephole	Plastic
87	1	Bleeder	Plastic
88	1	Lip seal	NBR
89	2	Lip seal	NBR

Hyclean SLR 5-125 / 5-150.

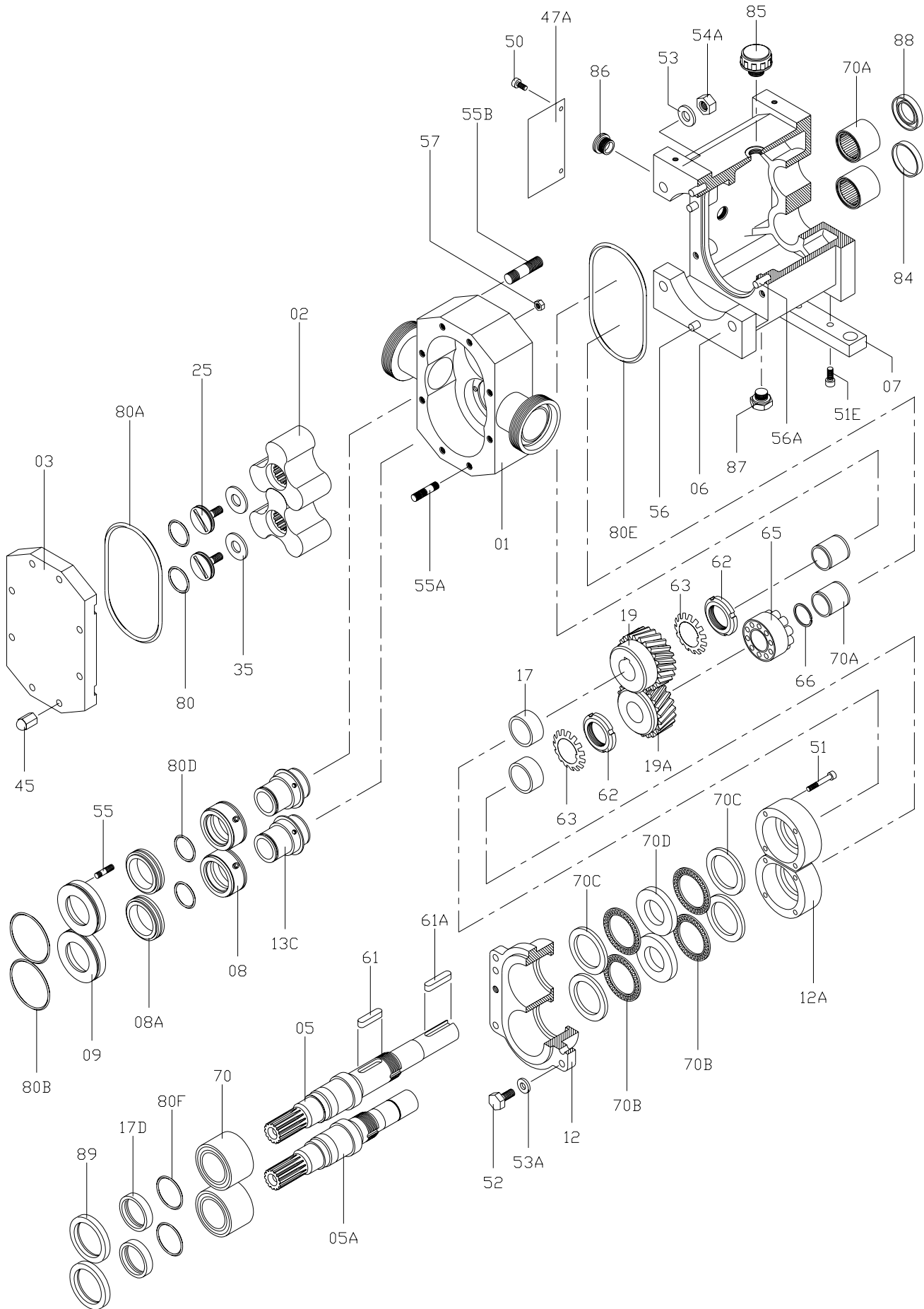

Parts list Hyclean SLR 5-125 / 5-150.

Position	Quantity	Description	Material
01	1	Pump housing	CF-8M
02	2	Trilobe	AISI-316
03	1	Pump cover	AISI-316
05	1	Drive shaft	AISI-329
05A	1	Driven shaft	AISI-329
06	1	Support	GG-15
07	2	Leg	AISI-304
12	1	Bearing cover	GG-15
12A	2	Bearing stop flange	GG-15
17	2	Drive shaft bushing	ST-52
17D	2	Driven shaft bushing	AISI-304
19	1	Drive shaft gear	F-154
19A	1	Driven shaft gear	F-154
25	2	Lobe screw	AISI-316
35	2	Lobe washer	AISI-316
45	8	Wing nut	AISI-304
47A	4	Protector	Plastic
50	4	Screw	A2
51	8	Allen screw	8.8
51E	6	Allen screw	A2
52	4	Hexagonal screw	8.8
53	4	Flat washer	A2
53A	4	Spring washer	8.8
54A	4	Hexagonal nut	A4
55A	8	Stud	A2
55B	4	Stud	A2
56	2	Pin	F-522
56A	2	Pin	F-522
61	1	Key	F-114
61A	1	Key	AISI-304
62	2	Safety nut	Steel
63	2	Safety washer	Steel
65	1	Conical tightening ring	Steel
66	1	Elastic ring	Steel
70	2	Ball bearings	Steel
70A	2	Needle bearings	Steel
70B	4	Axial bearing	Steel
70C	4	Axial disc	Steel
70D	2	Intermediate disc	Steel
80	2	O-ring	EPDM
80A	1	O-ring	EPDM
80B	2	O-ring	EPDM
80D	2	O-ring	EPDM
80E	1	O-ring	NBR
80F	2	O-ring	NBR
84	1	Blanking plug	NBR
85	1	Oil plug	Plastic
86	1	Peephole	Plastic
87	2	Bleeder	Plastic
88	1	Lip seal	NBR
89	2	Lip seal	NBR

Safety valve Hyclean.

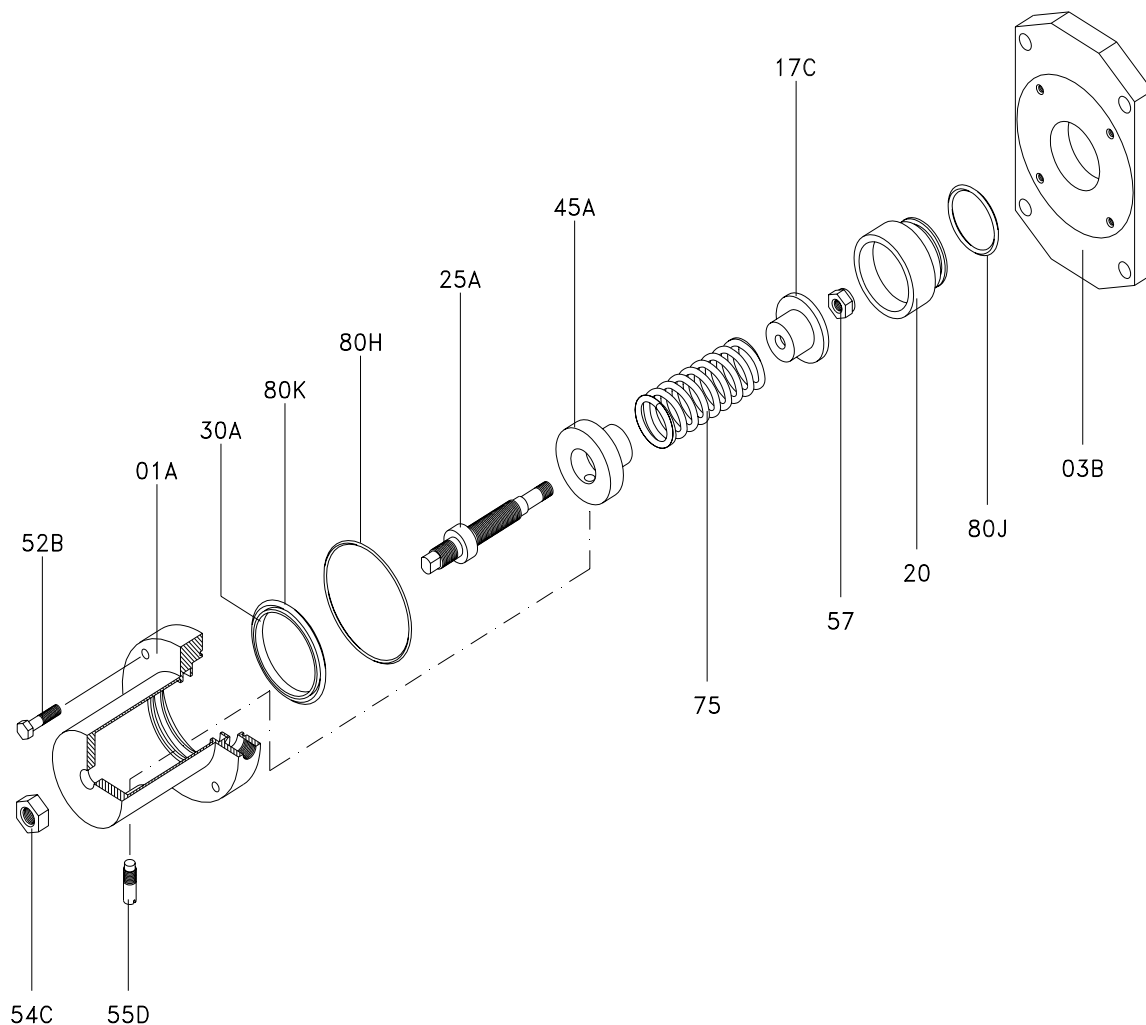

Position	Quantity	Description	Material
01A	1	Spring casing complete	AISI-304
03B	1	Pump cover for safety valve	AISI-316
17C	1	Spring plate	AISI-304
20	1	Piston	AISI-316
25A	1	Adjusting screw	AISI-304
30A	1	Guiding ring	PTFE
45A	1	Spring plate	AISI-304
52B	4	Hexagonal screw	A2
54C	1	Hexagonal nut	A2
55D	1	Locking pin	AISI-304
57	1	Self-locking nut	A2
75	1	Spring	AISI-301
80H	1	O-ring	EPDM
80J	1	O-ring	EPDM
80K	1	O-ring	EPDM

Front heating jacket Hyclean.

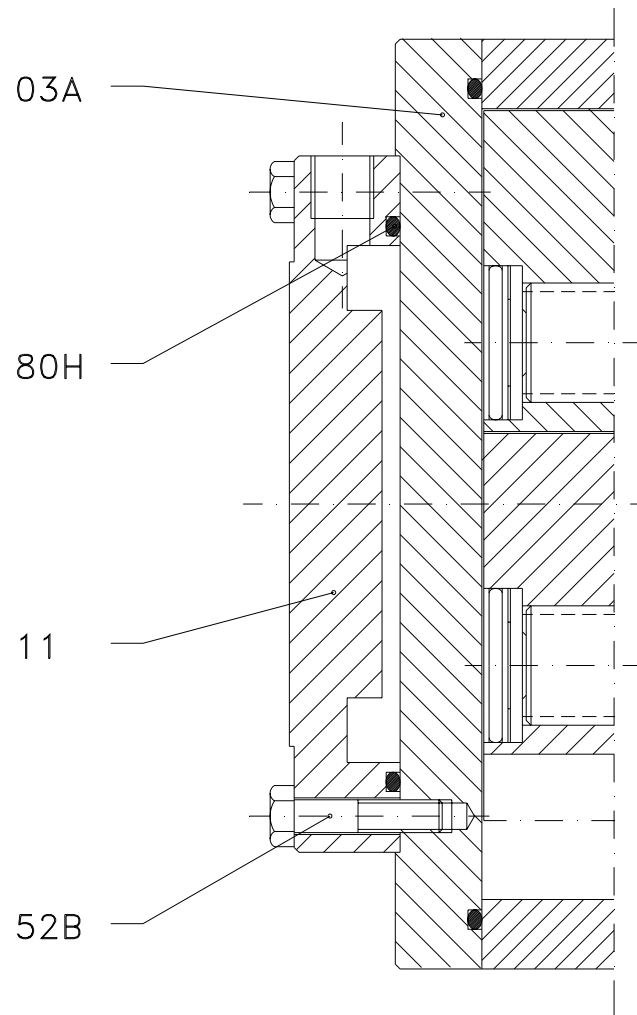

Position	Quantity	Description	Material
03A	1	Pump cover for heating jacket	AISI-316
11	1	Heating cover	AISI-304
52B	4	Hexagonal screw	A2
80H	1	O-ring	FPM

Heating jacket around shaft sealing Hyclean.

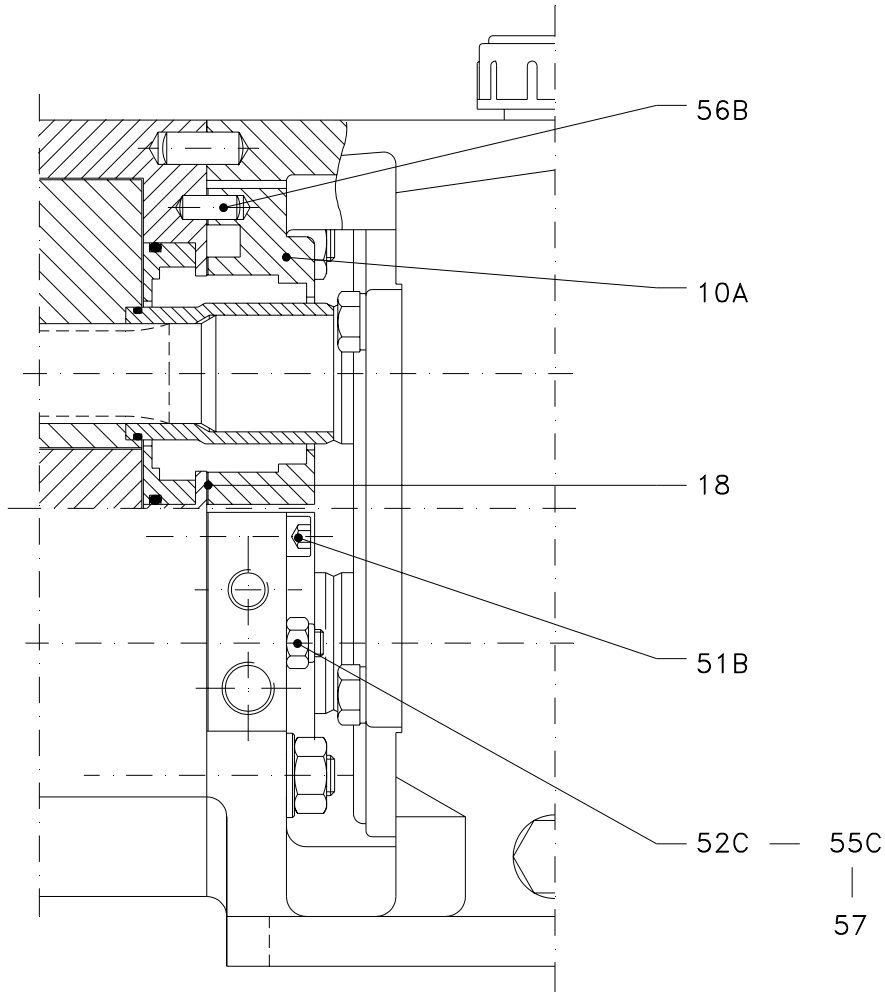

Position	Quantity	Description	Material
10A	2	Flushing cover with jacket	AISI-316
18	2	Gasket flushing	Graphite
51B	6	Allen screw -support 2-	A2
	8	Allen screw -support 3/4-	A2
52C	4	Hexagonal screw -support 2-	A2
55C	4	Stud -support 3/4-	A2
	8	Stud -support 5-	A2
56B	4	Pin	A2
57	4	Self-locking nut -support 3/4-	A2
	8	Self-locking nut -support 5-	A2

Heating jacket around shaft sealing Hyduty.

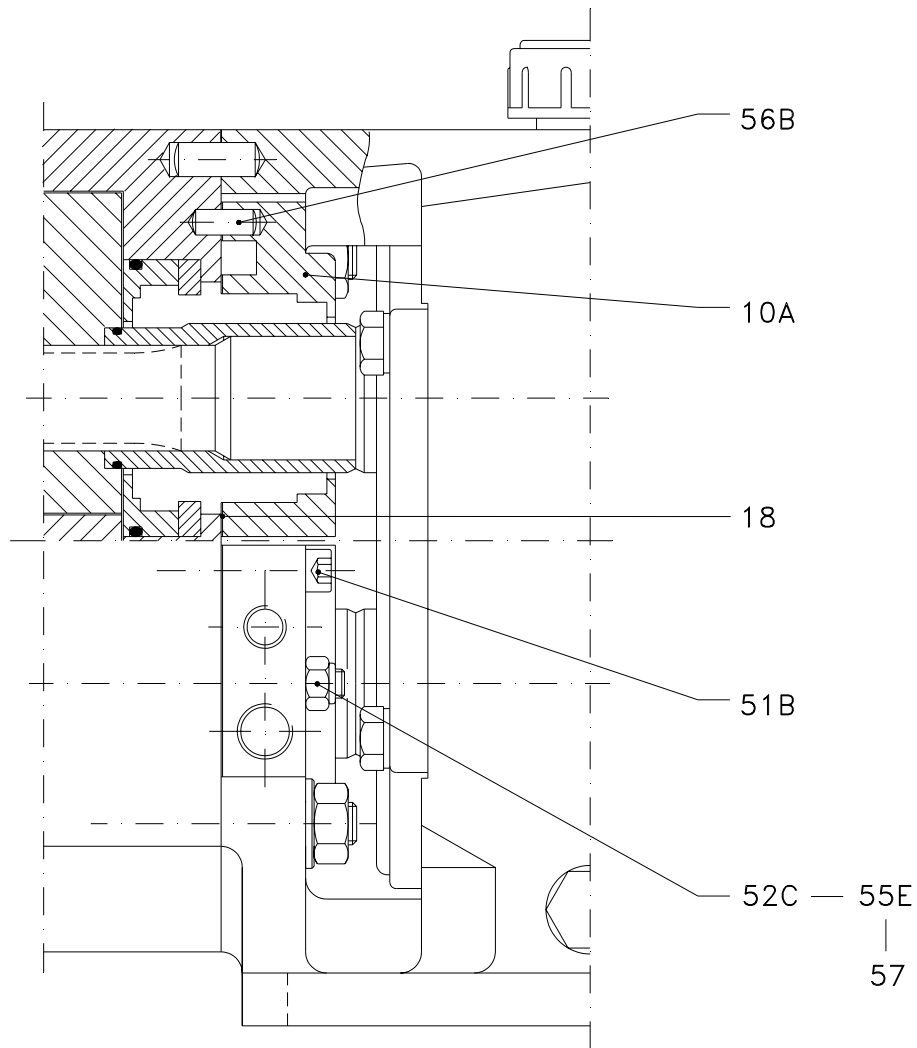

Position	Quantity	Description	Material
10A	2	Flushing cover with jacket	AISI-316
18	2	Gasket flushing	Graphite
51B	6	Allen screw -support 2-	A2
	8	Allen screw -support 3/4-	A2
52C	4	Hexagonal screw –support 2-	A2
55E	4	Stud	A2
56B	4	Pin	A2
57	4	Self-locking nut –support 3/4-	A2

Flushing SLR 0 - 1.

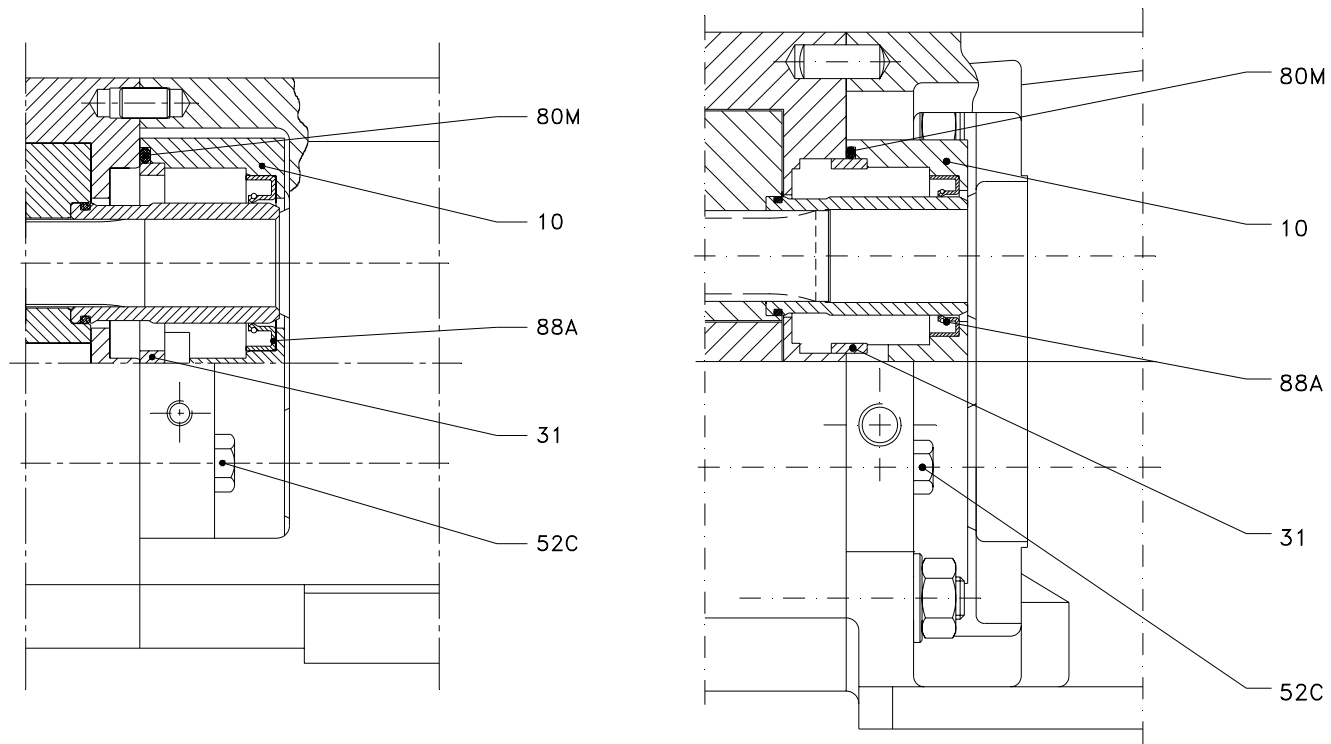

SLR 0

SLR 1

Position	Quantity	Description	Material
10	1	Flushing cover	AISI-316
31	2	Space sleeve	AISI-316
52C	4	Hexagonal screw	A2
80M	1	O-ring	FPM
88A	2	Lip seal	NBR

Flushing Hyclean SLR 2 - 3 - 4 - 5.

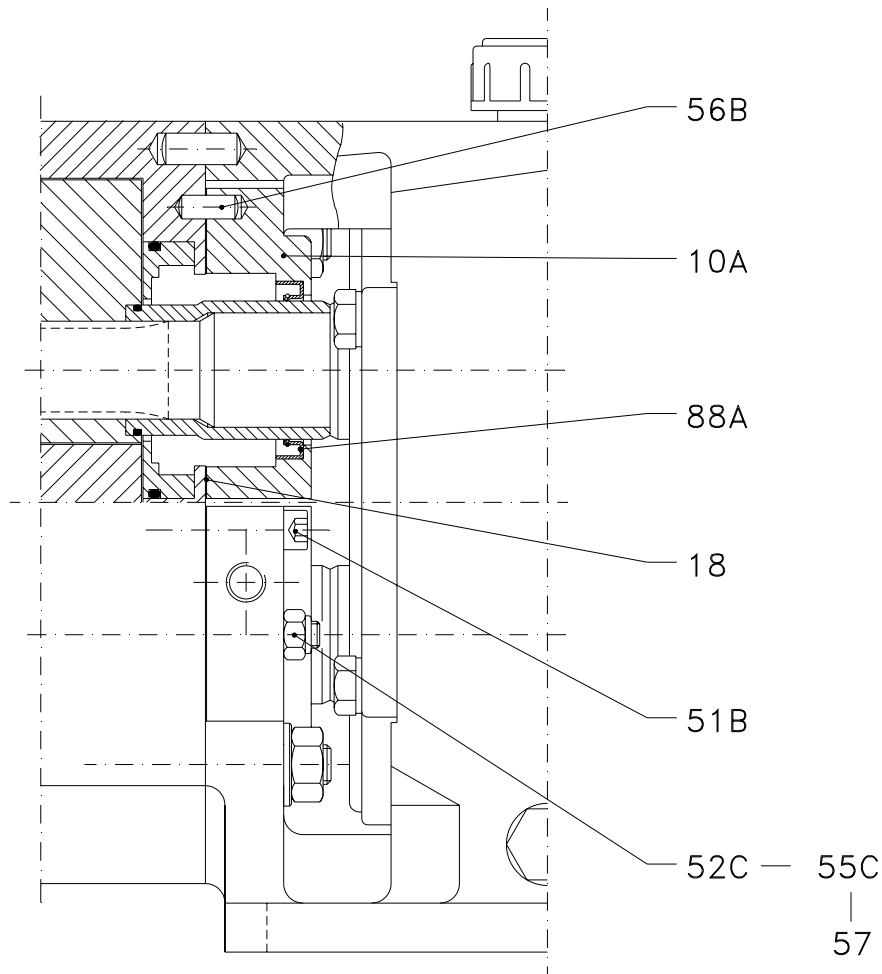

Position	Quantity	Description	Material
10A	2	Flushing cover	AISI-316
18	2	Gasket	Graphite
51B	6	Allen screw -support 2-	A2
	8	Allen screw -support 3/4-	A2
52C	4	Hexagonal screw -support 2-	A2
55C	4	Stud -support 3/4-	A2
	8	Stud -support 5-	A2
56B	4	Pin	A2
57	4	Self-locking nut -support 3/4-	A2
	8	Self-locking nut -support 5-	A2
88A	2	Lip seal	FPM

Flushing Hydutty SLR 2 - 3 - 4.

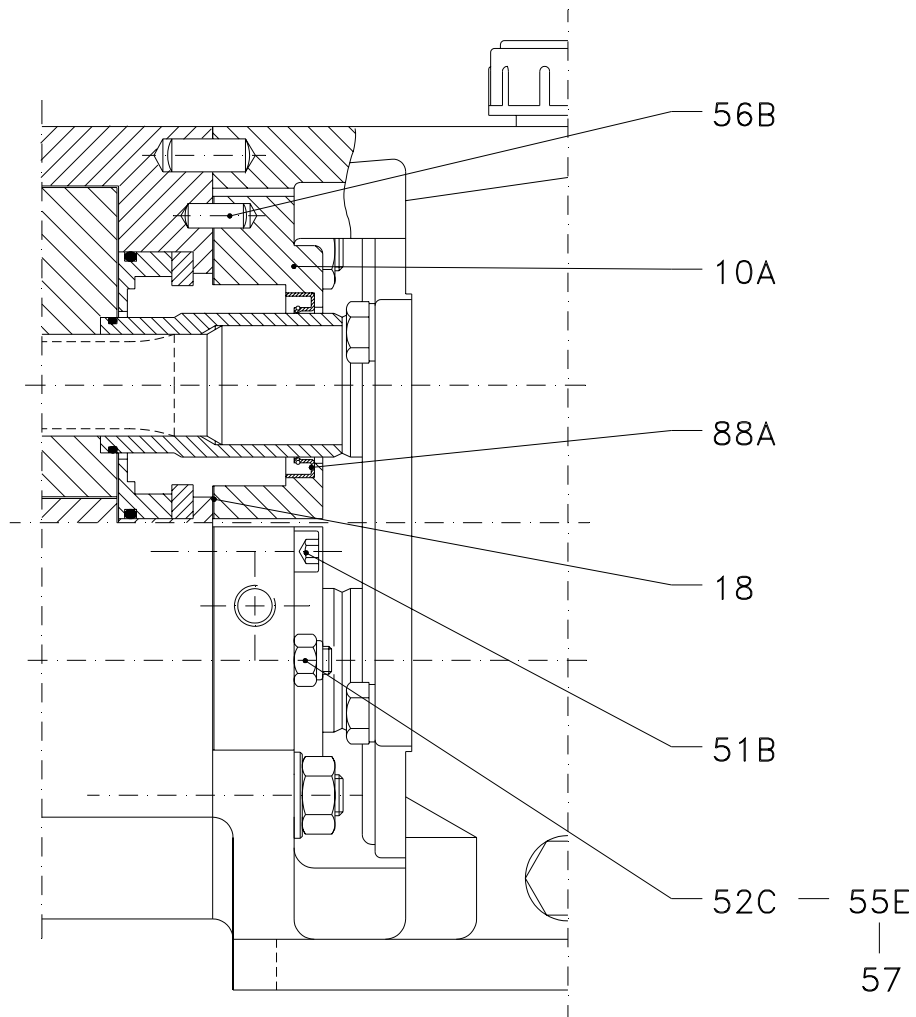

Position	Quantity	Description	Material
10A	2	Flushing cover	AISI-316
18	2	Gasket	Graphite
51B	6	Allen screw –support 2-	A2
	8	Allen screw –support 3/4-	A2
52C	4	Hexagonal screw –support 2-	A2
55E	4	Stud –support 3/4-	A2
56B	4	Pin	A2
57	4	Self-locking nut –support 3/4-	A2
88A	2	Lip seal	FPM

Single mechanical seal SLR 0 - 1.

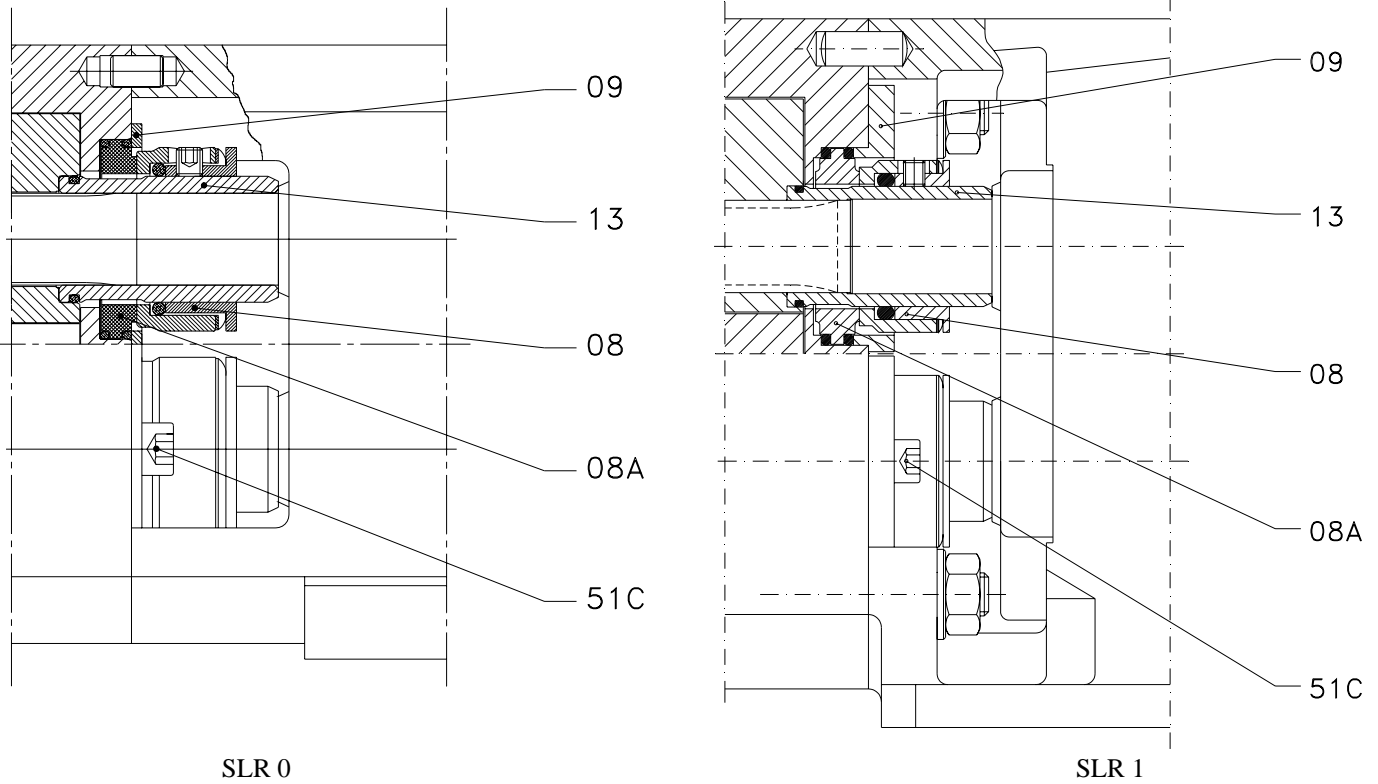

Position	Quantity	Description	Material
08	2	Mechanical seal –rotary part-	-
08A	2	Mechanical seal –stationary part-	-
09	2	Cover seal	AISI-304
13	2	Shaft sleeve	AISI-316
51C	4	Allen screw	A2

Single mechanical seal Hyclean SLR 2 - 3 - 4 - 5.

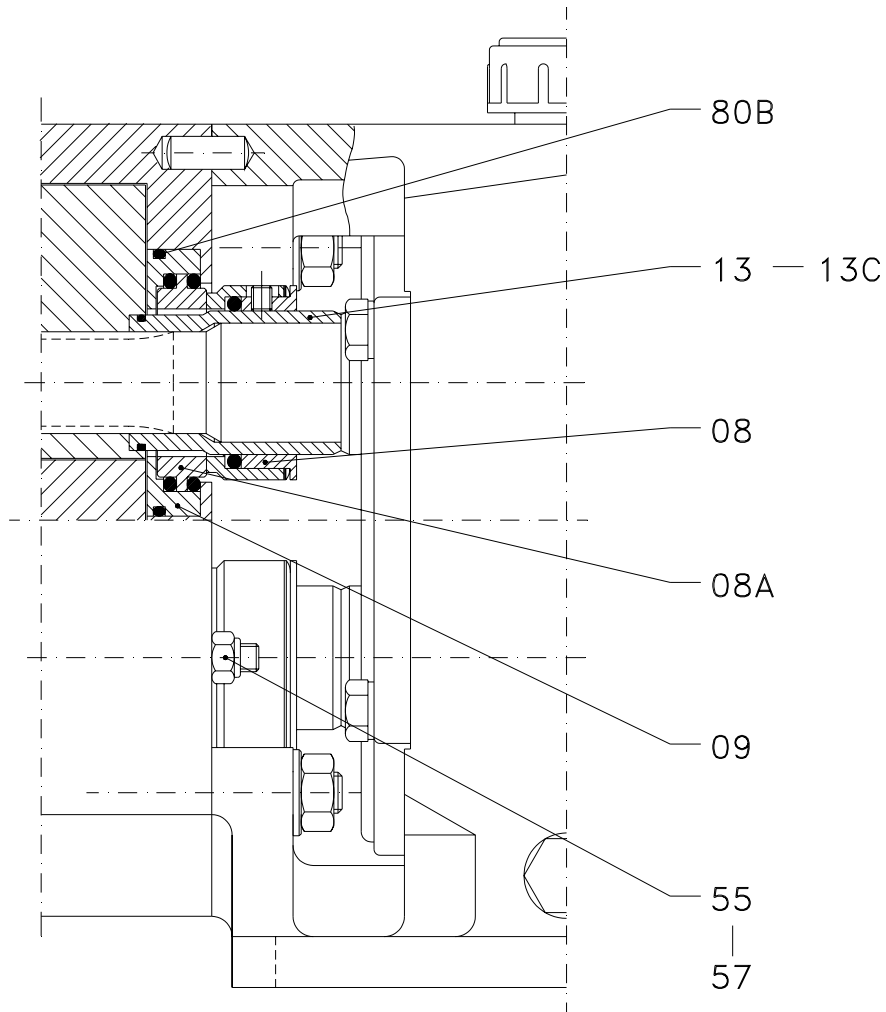

Position	Quantity	Description	Material
08	2	Mechanical seal –rotary part-	-
08A	2	Mechanical seal –stationary part-	-
09	2	Seal cover -cartridge-	AISI-316
13	2	Shaft sleeve –support 2/3-	AISI-316
13C	2	Shaft sleeve –support 4-	AISI-316
55	4	Stud -support 2/3/4-	A2
	8	Stud -support 5-	A2
57	4	Self-locking nut -support 2/3/4-	A2
	8	Self-locking nut -support 5-	A2
80B	2	O-ring	EPDM

Single mechanical seal Hyduty SLR 2 - 3 - 4.

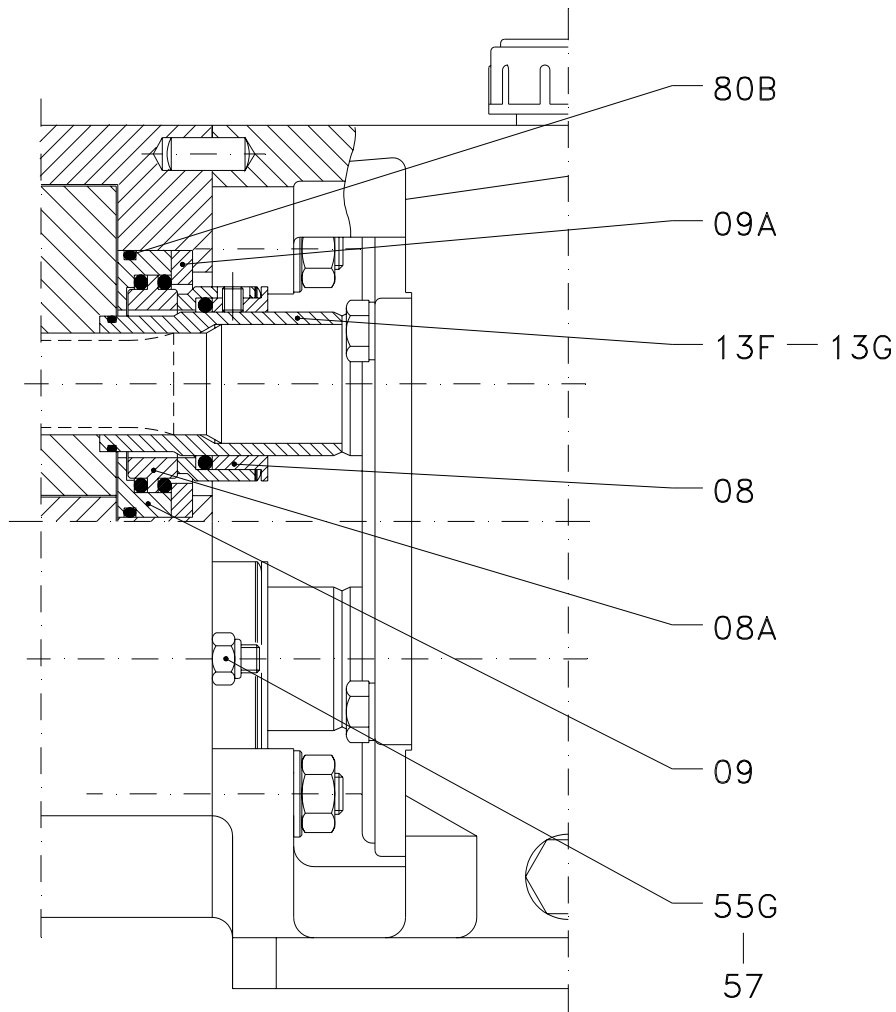

Position	Quantity	Description	Material
08	2	Mechanical seal –rotary part-	-
08A	2	Mechanical seal –stationary part-	-
09	2	Seal cover -cartridge-	AISI-316
09A	2	Supporting ring –cartridge-	AISI-316
13F	2	Shaft sleeve –support 2/3-	AISI-316
13G	2	Shaft sleeve –support 4-	AISI-316
55G	4	Stud	A2
57	4	Self-locking nut	A2
80B	2	O-ring	EPDM

Lip seal PTFE SLR 0 - 1.

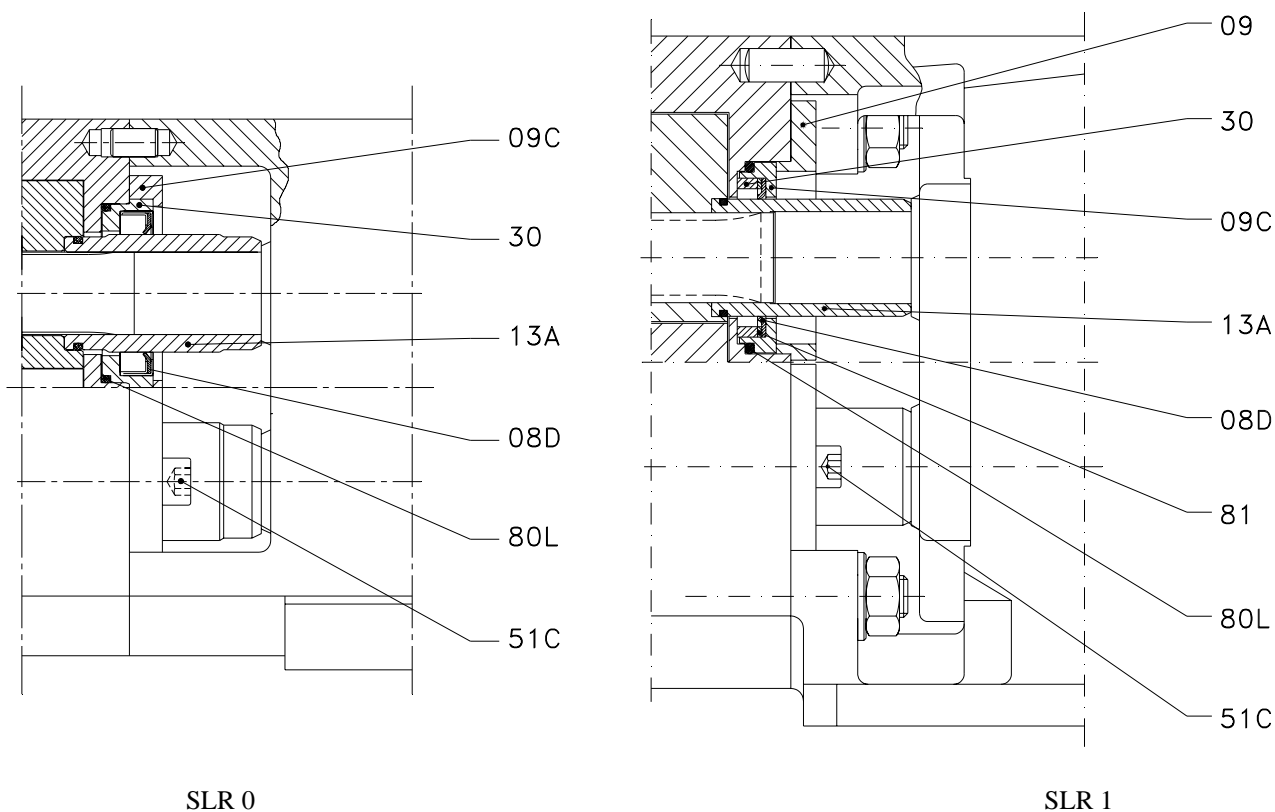

Position	Quantity	Description	Material
08D	2	Lip seal	PTFE
09	2	Cover seal	AISI-304
09C	2	Supporting ring - support 1 -	AISI-316
13A	2	Shaft sleeve	AISI-316
30	2	Lip seal spacer - support 1 -	AISI-316
51C	4	Allen screw	A2
80L	2	O-ring	EPDM
81	2	Flat seal - support 1 -	FPM

Lip seal PTFE Hyclean SLR 2 - 3 - 4 - 5.

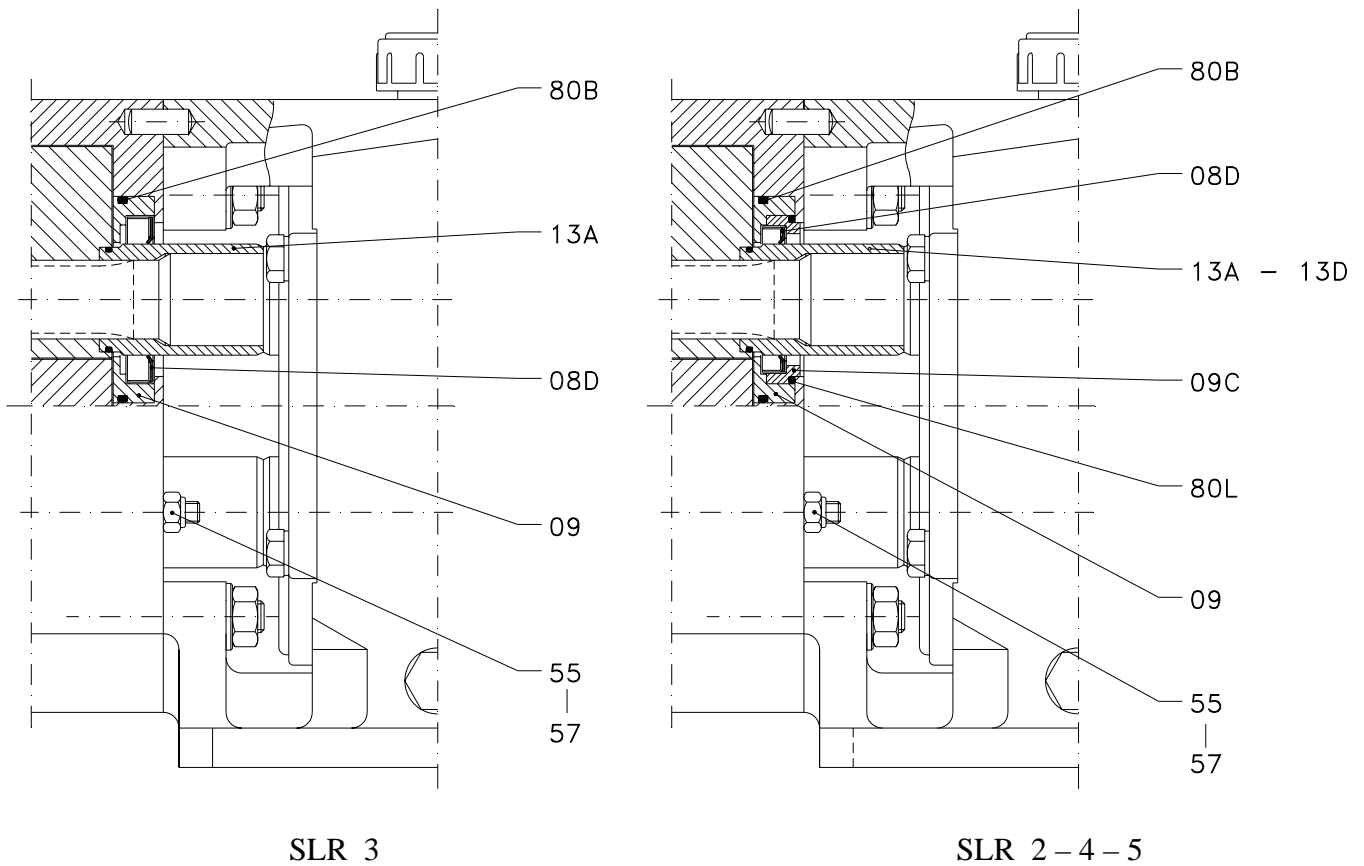

Position	Quantity	Description	Material
08D	2	Lip seal	PTFE
09	2	Cover seal -cartridge-	AISI-316
09C	2	Supporting ring -support 2/4/5 -	AISI-316
13A	2	Shaft sleeve -support 2/3 -	AISI-316
13D	2	Shaft sleeve -support 4/5 -	AISI-316
55	4	Stud -support 2/3/4 -	A2
	8	Stud -support 5 -	A2
57	4	Self-locking nut -support 2/3/4 -	A2
	8	Self-locking nut -support 5 -	A2
80B	2	O-ring	EPDM
80L	2	O-ring-support 2/4/5 -	EPDM

Lip seal PTFE Hyduty SLR 2 - 3 - 4.

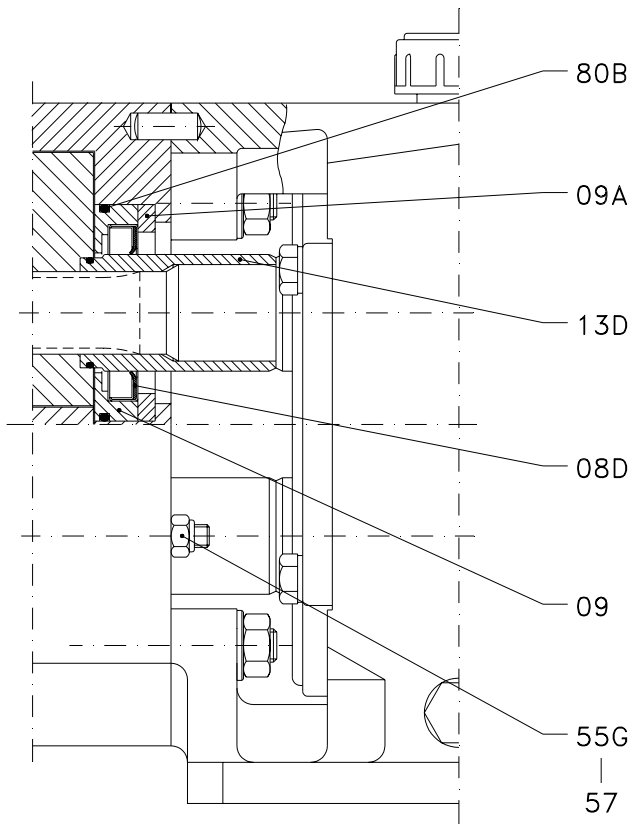

SLR 3

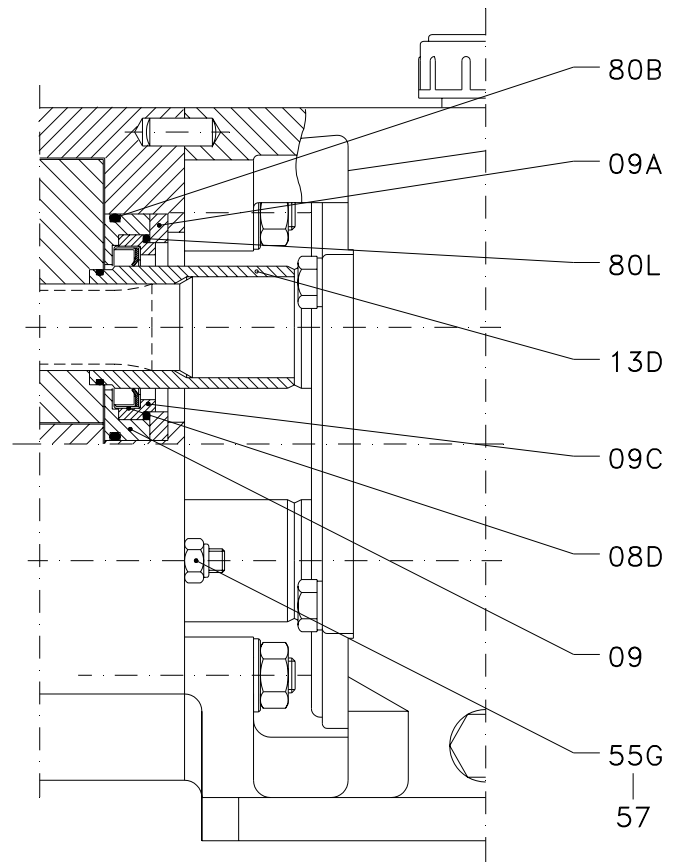

SLR 2-4

Position	Quantity	Description	Material
08D	2	Lip seal	PTFE
09	2	Cover seal -cartridge-	AISI-316
09A	2	Spacer sleeve -cartridge-	AISI-316
09C	2	Supporting ring – support 2/4 -	AISI-316
13D	2	Shaft sleeve	AISI-316
55G	4	Stud	A2
57	4	Self-locking nut	A2
80B	2	O-ring	EPDM
80L	2	O-ring – support 2/4 -	EPDM

O-ring SLR 0 - 1.

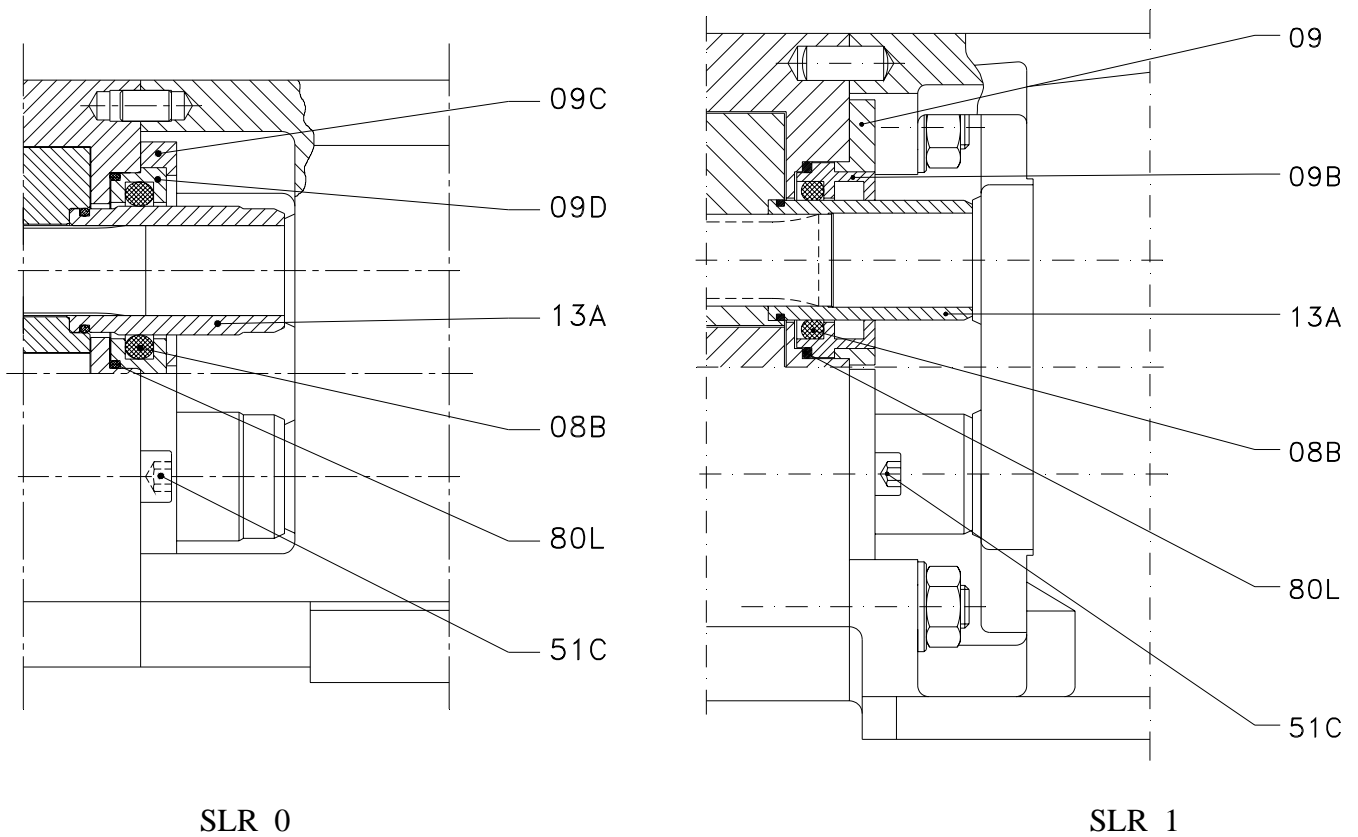

Position	Quantity	Description	Material
08B	2	O-ring seal	-
09	2	Cover seal –support 1-	AISI-304
09B	2	Cover O-ring - support 1 -	AISI-316
09C	2	Cover seal –support 0-	AISI-304
09D	2	Cover O-ring - support 0 -	AISI-316
13A	2	Shaft sleeve	AISI-316
51C	4	Allen screw	A2
80L	2	O-ring	EPDM

O-ring Hyclean SLR 2 - 3 - 4 - 5.

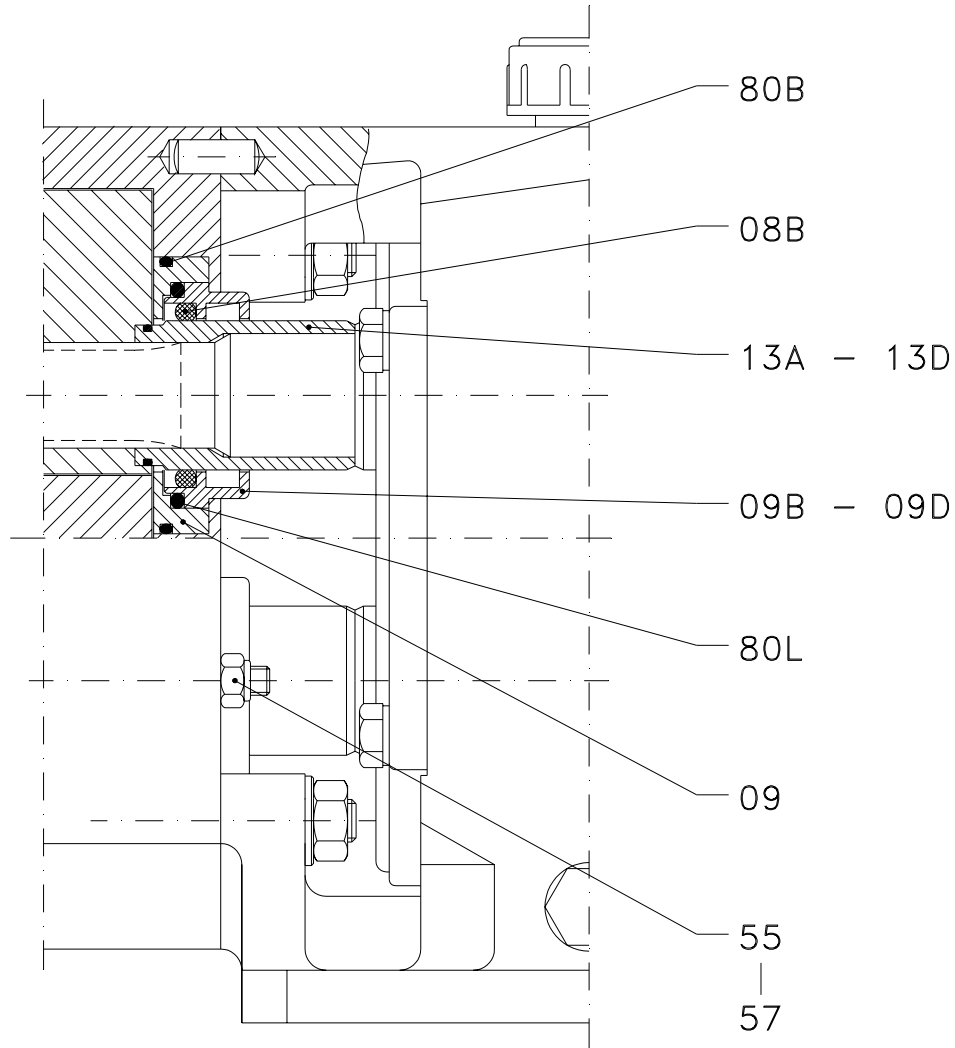

Position	Quantity	Description	Material
08B	2	O-ring seal	-
09	2	Cover seal -cartridge-	AISI-316
09B	2	Cover O-ring -support 2/3-	AISI-316
09D	2	Cover O-ring -support 4/5-	AISI-316
13A	2	Shaft sleeve -support 2/3-	AISI-316
13D	2	Shaft sleeve -support 4/5-	AISI-316
55	4	Stud -support 2/3/4-	A2
	8	Stud -support 5-	A2
57	4	Self-locking nut -support 2/3/4-	A2
	8	Self-locking nut -support 5-	A2
80B	2	O-ring	EPDM
80L	2	O-ring	EPDM

O-ring Hyduty SLR 2 - 3 - 4 .

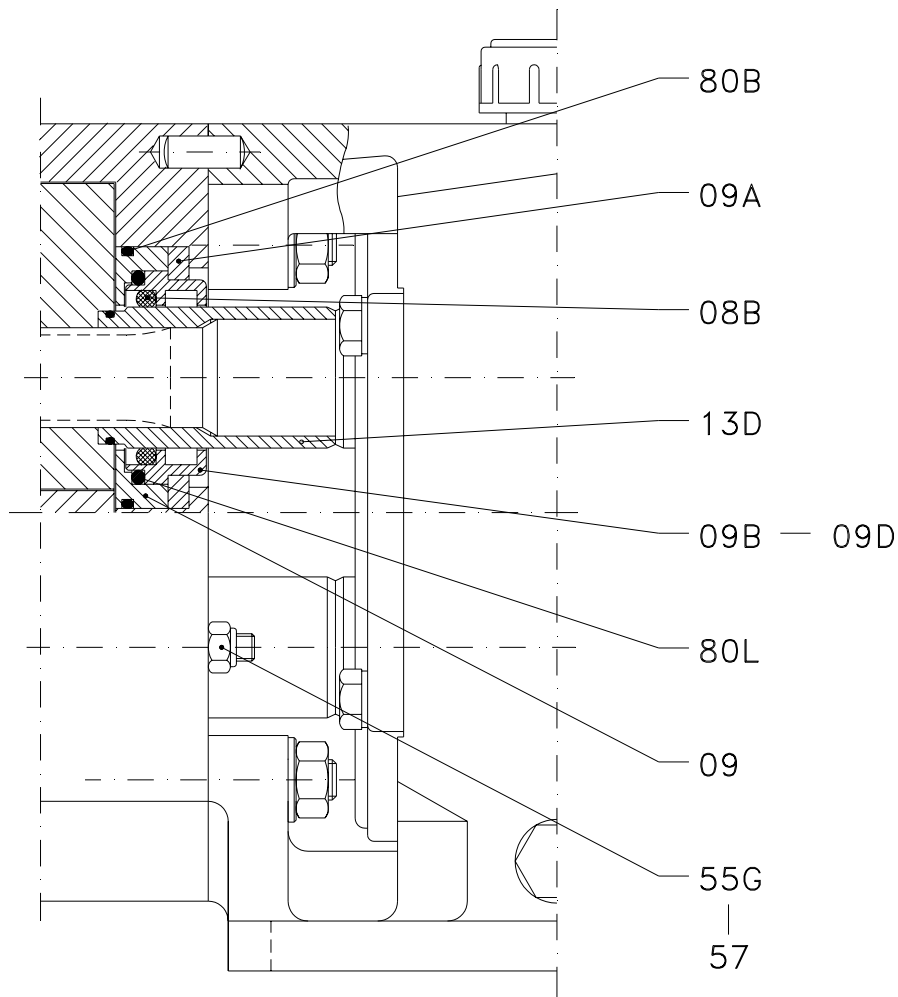

Position	Quantity	Description	Material
08B	2	O-ring seal	-
09	2	Cover seal -cartridge-	AISI-316
09A	2	Supporting seal	AISI-316
09B	2	Cover O-ring -support 2/3-	AISI-316
09D	2	Cover O-ring -support 4-	AISI-316
13D	2	Shaft sleeve	AISI-316
55G	4	Stud	A2
57	4	Self-locking nut	A2
80B	2	O-ring	EPDM
80L	2	O-ring	EPDM

Lip seal INOXPA SLR 0 - 1.

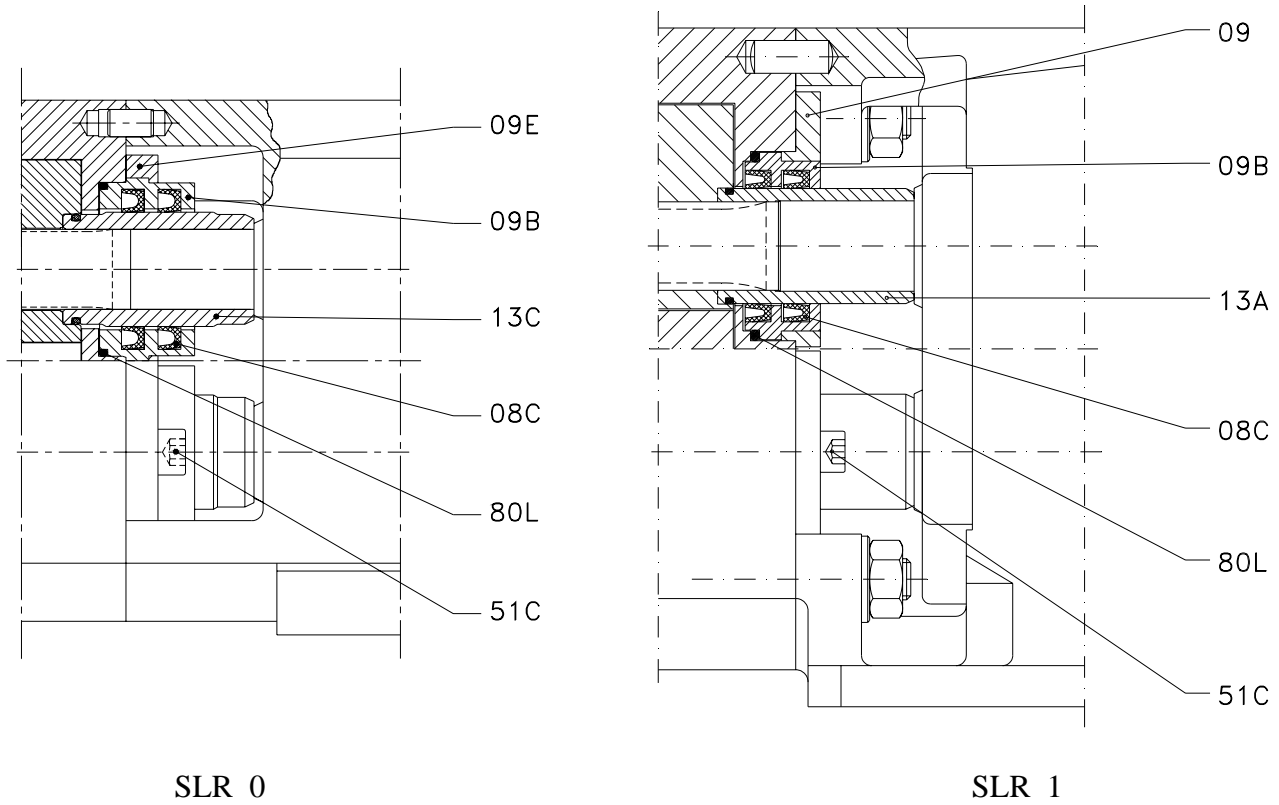

Position	Quantity	Description	Material
08C	4	O-ring seal INOXPA	-
09	2	Cover seal -support 1-	AISI-304
09B	2	Supporting ring	AISI-316
09E	1	Cover seal -support 0-	AISI-304
13A	2	Shaft sleeve -support 1-	AISI-316
13C	2	Shaft sleeve -support 0-	AISI-316
51C	4	Allen screw	A2
80L	2	O-ring	EPDM

Lip seal INOXPA Hyclean SLR 2 - 3 - 4 - 5.

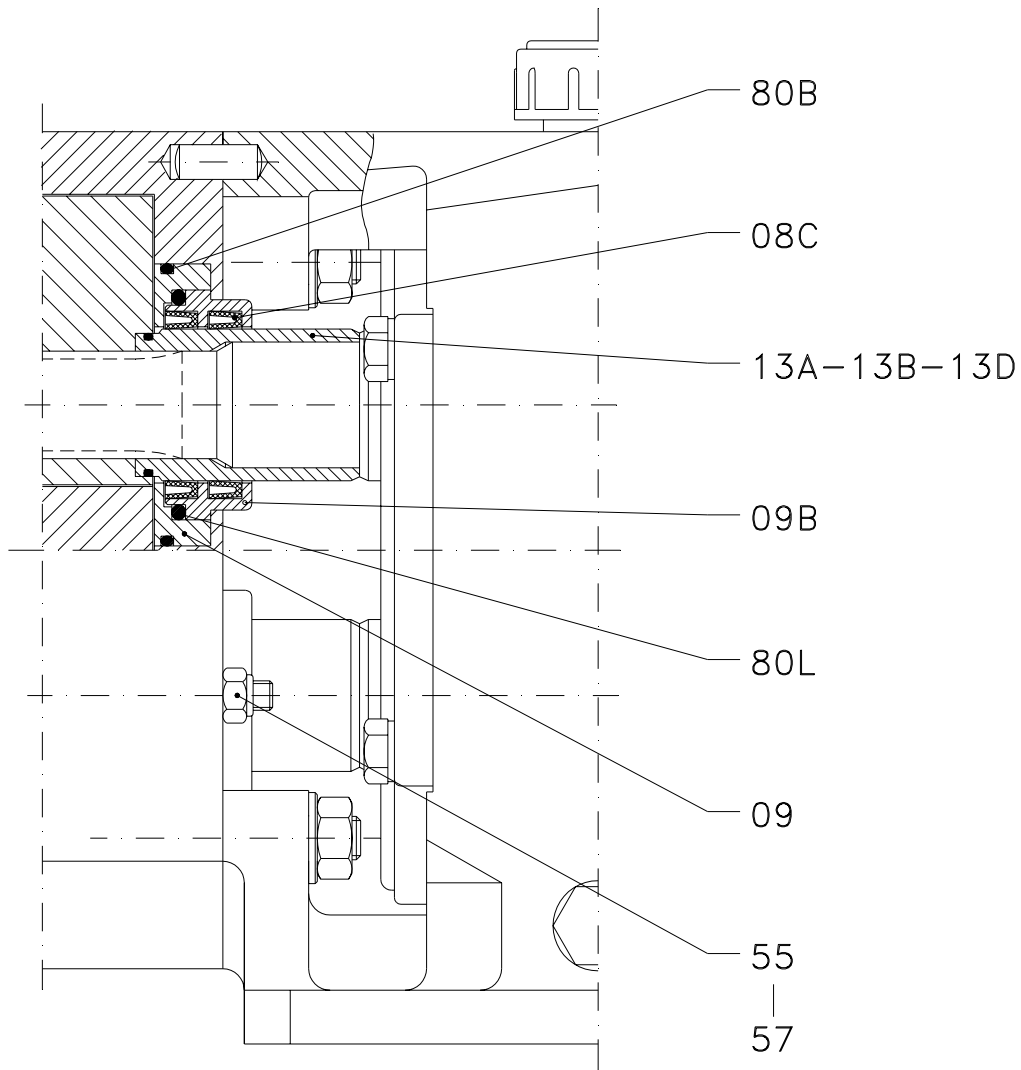

Position	Quantity	Description	Material
08C	4	Lip seal INOXPA	-
09	2	Cover seal -cartridge-	AISI-316
09B	2	Supporting ring	AISI-316
13A	2	Shaft sleeve -support 2-	AISI-316
13B	2	Shaft sleeve -support 3-	AISI-316
13D	2	Shaft sleeve -support 4/5-	AISI-316
55	4	Stud -support 2/3/4-	A2
	8	Stud -support 5-	A2
57	4	Self-locking nut -support 2/3/4-	A2
	8	Self-locking nut -support 5-	A2
80B	2	O-ring	EPDM
80L	2	O-ring	EPDM

Lip seal INOXPA Hyduty SLR 2 - 3 - 4.

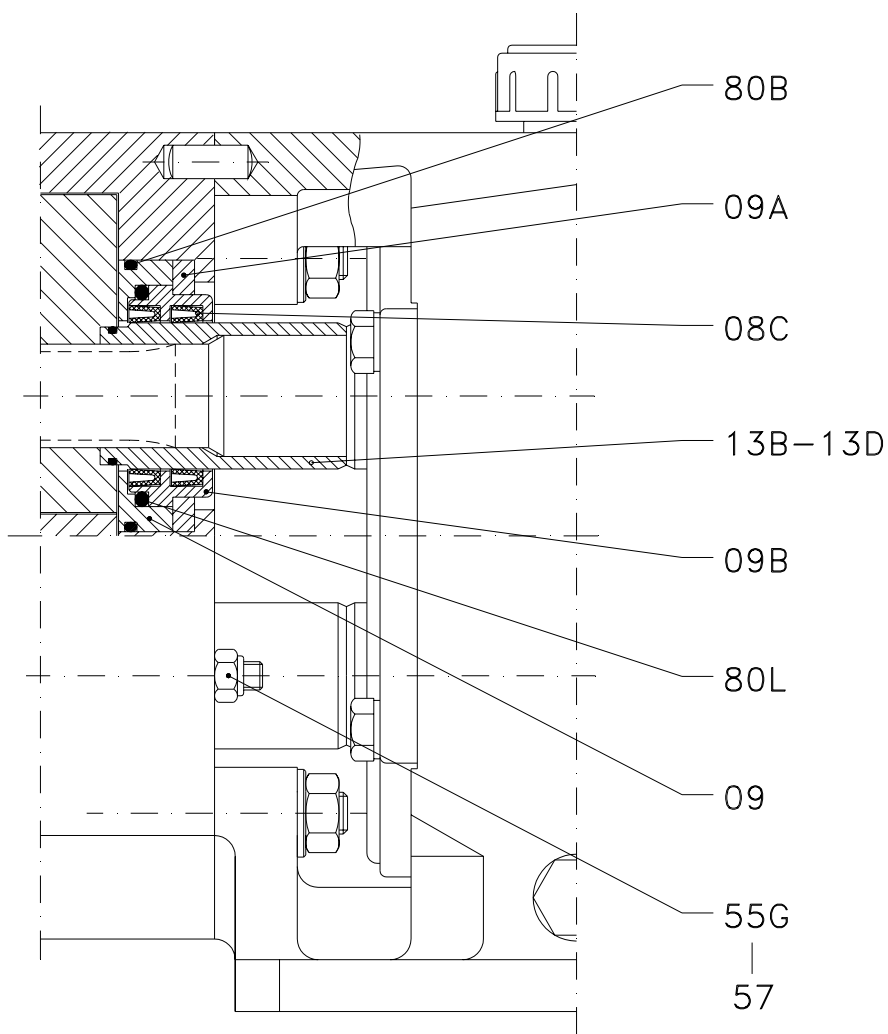

Position	Quantity	Description	Material
08C	4	Lip seal INOXPA	-
09	2	Cover seal -cartridge-	AISI-316
09A	2	Seal retainer	AISI-316
09B	2	Spacer sleeve	AISI-316
13B	2	Shaft sleeve -support 3-	AISI-316
13D	2	Shaft sleeve -support 2/4-	AISI-316
55G	4	Stud	A2
57	4	Self-locking nut	A2
80B	2	O-ring	EPDM
80L	2	O-ring	EPDM

Packing gland SLR.

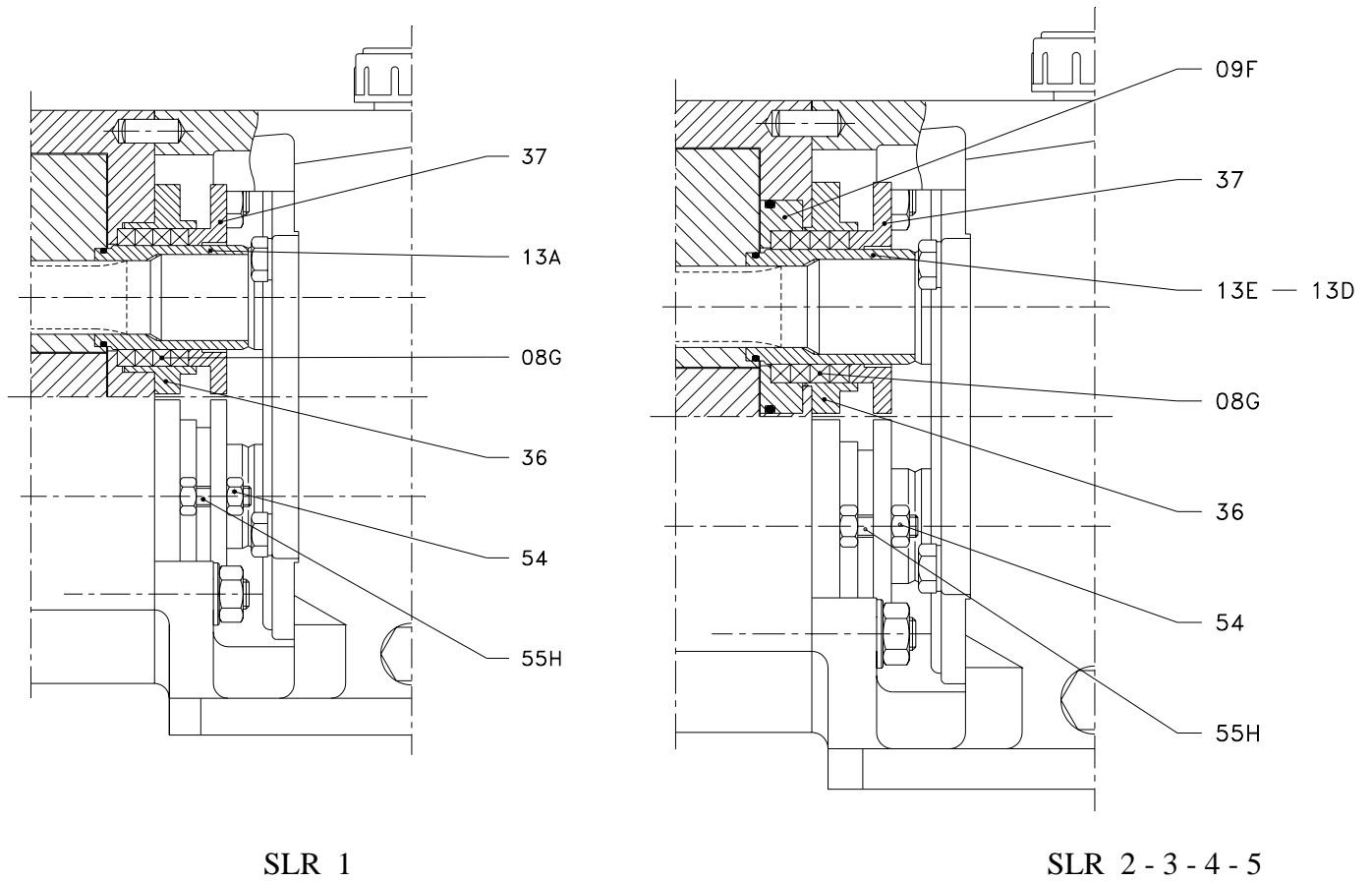

Posición	Cantidad	Descripción	Material
08G	8	Fitting packing	Amianto teflón
09F	2	Cover packing - support 2/3/4/5 -	AISI-316
13A	2	Shaft sleeve -support 1-	AISI-316
13E	2	Shaft sleeve -support 2/3-	AISI-316
13D	2	Shaft sleeve -support 4/5-	AISI-316
36	2	Casing packing	AISI-316
37	2	Stuffing box	AISI-316
54	8	Hexagonal nut	A2
55H	4	Stud	A2

Single mechanical seal DIN 24960 Hyduty SLR 2 - 3 - 4.

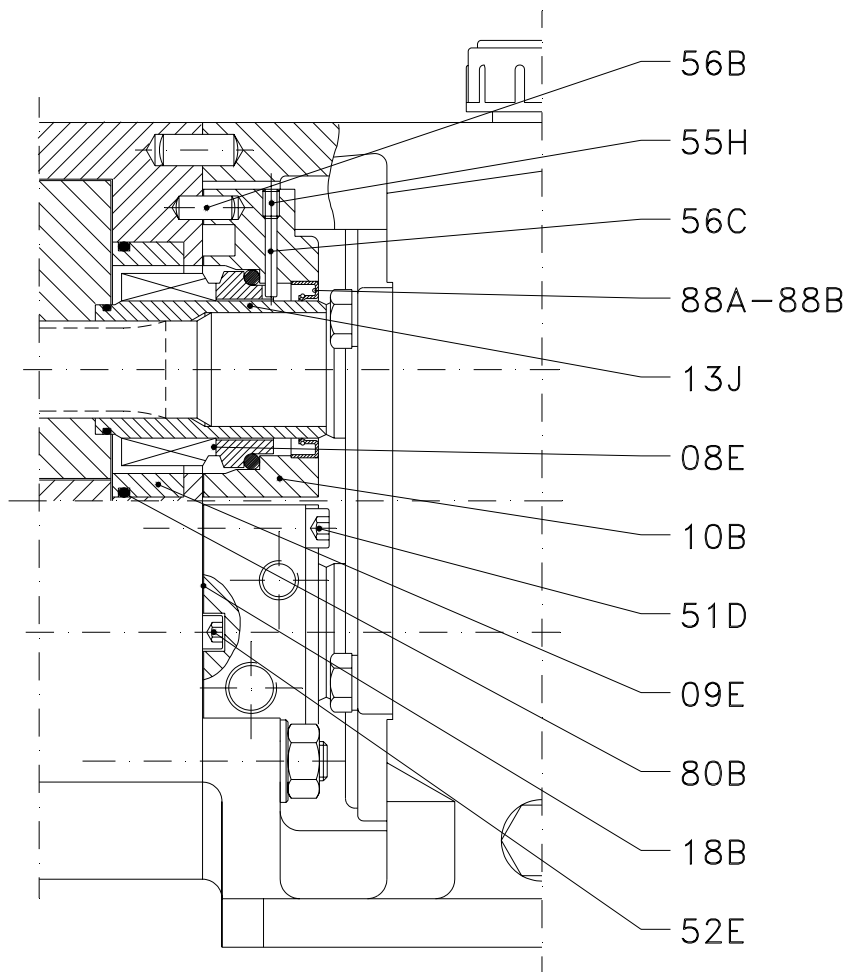

Position	Quantity	Description	Material
08E	2	DIN seal	-
09E	2	Filing ring	AISI-316
10B	2	Cover with flush and/or heating	AISI-316
13J	2	Shaft sleeve	AISI-316
18B	2	Flat gasket	Graphite
51D	6	Allen screw -support 2-	A2
51D	8	Allen screw -support 3/4-	A2
52E	4	Allen screw	A2
55H	2	Stud	A2
56B	4	Pin	A2
56C	2	Pin	A2
80B	2	O-ring	EPDM
88A	2	Lip seal -support 2/3-	NBR
88B	2	Lip seal -support 4-	NBR

Double mechanical seal Hyduty SLR 2 - 3 - 4.

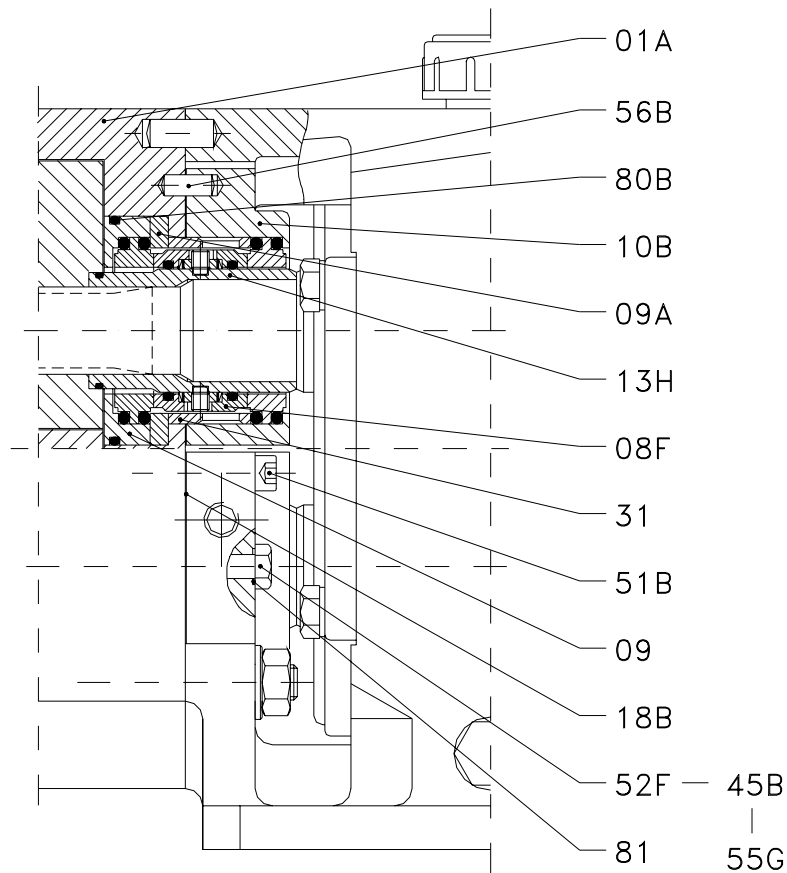

Position	Quantity	Description	Material
01A	1	Pump housing - support 3/4 -	AISI-316
08F	2	Double mechanical seal	-
09	2	Cover seal - support 3/4 -	AISI-316
09A	2	Spacer sleeve	AISI-316
10B	2	Cover double seal	AISI-316
13H	2	Shaft sleeve	AISI-316
18B	2	Flat gasket	Graphite
31	2	Separator	AISI-316
45B	8	Bling nut - support 4 -	AISI-304
51B	6	Allen screw - support 2 -	A2
	8	Allen screw - support 3/4 -	A2
52F	4	Hexagonal screw - support 2 -	A2
	8	Hexagonal screw - support 3 -	A2
55G	8	Threaded rod - support 4 -	A2
56B	4	Pin	A2
80B	2	O-ring	EPDM
81	4	Flat seal - support 2 -	PTFE
	8	Flat seal - support 3/4 -	PTFE

10. Cleaning and Disinfection.

GENERAL CONSIDERATIONS.

Cleaning and disinfection of the installations is necessary and mandatory on completing any manufacturing process in the food industry. The use of an installation which is NOT cleaned or disinfected can cause contamination of the products.

The cleaning cycles as well as the chemical products and procedures used will vary depending on the product and the manufacturing process.

It is the user's responsibility to establish an appropriate cleaning or disinfection program according to his needs. Such a program needs to take into account all applicable laws, regulations and standards pertinent to public health protection and safety in the use of chemical products.

HYGIENE.

Special attention has been given to hygiene and cleaning and disinfection operations in the design of the SLR pump. The number of grooves and dead spaces have been kept to a minimum. The materials used in making the pump have been selected for their resistance to corrosion and so as not to contaminate the liquid to be pumped.

Cleaning.

The pump can be cleaned easily and thoroughly in one of two ways:

- without disassembling it, for ex., using steam or water, referred to as CIP ("Cleaning in Place).
- by simply disassembling the pump cover, the lobes, the pump cover and the mechanical seal (see Assembly and Disassembly).

Once the pump has been cleaned, all the parts that have been in contact with the cleaning products and the disinfectant have to be rinsed with water.

It is important that the pump be running during the CIP process in order to obtain the most thorough cleaning.

During the automated CIP processes the pump could be started up unexpectedly because of some remote signal. This could cause serious damage to anyone who is in contact with the pump.



NEVER disassembly the pump during the CIP cleaning process. Disconnect the electrical supply to the pump and take those steps which are needed for safety before beginning any manual cleaning operation on the pump.

Direct contact with cleaning or disinfecting solutions can provoke burns due to chemical agents or high temperatures.



Provide personnel responsible for cleaning operations with adequate protective equipment --clothing, footwear, safety glasses-- in order to avoid any hazard.

Train personnel in the safe use and handling of chemical solutions and high working temperatures.

Disinfection.

Disinfection cycles are used to kill bacteria on the surfaces in contact with the product before the manufacturing process takes place. Disinfecting solutions are extremely corrosive, especially those which contain halogen components (chloride, bromide, iodine) or strong acids (nitric, hydrochloric).

When metal parts are allowed to remain in contact for a longer period of time with the solutions containing chemical agents, even these attack the stainless steel parts of a pump. To avoid serious damage:

- **Do NOT disinfect the pump earlier than 15 minutes before beginning production.**



- **Do NOT leave disinfecting solutions in prolonged contact with pump surfaces or the outside of it. Drops of dried solution are more concentrated and can provoke corrosion points or pitting.**

- **Do NOT use strong concentrations, high temperatures or exposure times over and above those required to obtain an effective disinfection.**

SAFETY IN CLEANING AND DISINFECTION.**Manual cleaning.**

- **Disconnect the motor starting system before cleaning the pump.**
- **Provide cleaning personnel with the most appropriate protective equipment -clothing, footwear, safety glasses.**
- **Do not use toxic or inflammable solvents for cleaning the pump.**
- **Clean up any water spilled around the pump as soon as possible.**
- **With the pump running, NEVER clean it by hand.**

**CIP Procedure.**

- **Make sure that all cleaning circuit connections are securely tightened so as to avoid splashing of hot water or cleaning solutions.**
 - **Establish a safety device in the event of any failure in the automatic process and avoid automatic start-up.**
 - **Check to see that the pump housing are well-positioned and securely tightened.**
- **Do not disassemble any pipes, fittings or the pump without being sure that the cleaning cycle is completely finished.**

For reference purposes for the user, the cleaning methods and products used can be those mentioned in the DIN 11483 standard